



NIAGARA REGION
WATER-WASTEWATER PROJECT DESIGN MANUAL
(ENG-PM-ALL-MAN-001)

REVISION 3
EFFECTIVE JULY 2023

Table of Contents

Introduction	1
SECTION A - GENERAL	2
A.1 Document Scope	2
A.2 Reference Documents	2
A.3 Designer Responsibilities	3
A.3.1 Approvals and Permits	3
A.3.2 Non-Compliance with Design Manual	3
A.3.3 Level of Service and Backup (Redundant) Equipment	3
A.3.4 Risk Assessment	3
A.3.5 Hazard and Operability Review	4
A.3.6 Health and Safety	5
A.3.7 Security	6
A.3.8 Tender Documents	6
A.3.9 Operations Manual	6
A.3.10 Energy Efficient Design	6
A.4 Design Disciplines.....	7
A.4.1 General	7
A.4.2 Civil	7
A.4.3 Architectural.....	11
A.4.4 Structural	12
A.4.5 Process Mechanical	14
A.4.6 Heating, Venting and Air Conditioning (HVAC).....	21
A.4.7 Standby Power	22
A.4.8 Electrical	25
A.4.9 Instrumentation and Control	28
SECTION B - Water.....	30
B.1 Water Treatment Plants	30
B.1.1 Design Vision.....	30
B.1.2 Basis of Design.....	30
B.1.3 Facility Layout.....	30
B.1.4 Treatment Processes and Equipment	31
B.2 Water Transmission Systems	37
B.2.1 Design Vision.....	37
B.2.2 Basis of Design.....	37
B.2.3 System Layout.....	38
B.2.4 Pipe Requirements	38
B.3 Water Booster Pumping Stations	42
B.3.1 Design Vision.....	42
B.3.2 Basis of Design.....	42
B.3.3 Facility Layout.....	43
B.3.4 Process Equipment	43
B.3.5 Process Control	44
B.4 Potable Water Storage	44
B.4.1 All Potable Water Storage Facilities (Reservoirs and Elevated Tanks)	44
B.4.2 Reservoir Storage Requirements	47
B.4.3 Elevated Tank Requirements	49
B.5 Chlorination Booster Systems.....	50
B.5.1 Design Vision.....	50
B.5.2 Basis of Design.....	51
B.5.3 Facility Layout.....	51

B.5.4 Process Equipment	51
SECTION C - Wastewater.....	52
C.1 Wastewater Linear Systems.....	52
C.1.1 Design Vision.....	52
C.1.2 Basis of Design.....	52
C.1.3 System Layout.....	55
C.1.4 Pipe Material.....	55
C.1.5 Maintenance Holes	56
C.1.6 Forcemains	57
C.2 Wastewater Pumping Stations.....	61
C.2.1 Design Vision.....	61
C.2.2 Basis of Design.....	61
C.2.3 Facility Layout.....	66
C.2.4 Process Equipment	66
C.2.5 Process Pump Controls.....	68
C.2.6 Wet Well / Dry Well Pumping Stations	68
C.3 Wastewater Treatment Plants	69
C.3.1 Design Vision.....	69
C.3.2 Facility Layout.....	69
C.3.3 Treatment Processes and Equipment	70
C.3.4 Energy Efficient Treatment Plant.....	76
C.3.5 Biosolids Management	78
Appendix A - Glossary	79
Appendix B – Schematics	83
Appendix C - Acts, Codes, Standards and Guidelines	90

Introduction

The Water and Wastewater Services of Niagara Region have developed this Project Design Manual as a guide for staff and consulting engineers involved in the implementation of water and wastewater capital works projects within the Niagara Region. This manual provides design preferences and guidelines that must be used as minimum requirements of Niagara Region. Design consulting engineers shall ensure all applicable legislations, codes, bylaws and standards are met for the project along with design preferences described within this document. Niagara Region encourages all designers to utilize sound professional judgment, industry best practices, innovation, creativity and ingenuity within their designs.

Any project specific deviations to this manual shall be discussed and approved by Niagara Region staff prior to implementation.

SECTION A - GENERAL

A.1 Document Scope

This document is intended to be used for all water and wastewater (W&WW) projects implemented by the Capital Works Program, including Operational and Maintenance projects, of the Public Works Department of Niagara Region. Niagara Region expects that all staff and design consulting engineers and suppliers will become familiar with and comply with the design preferences described within this manual unless otherwise noted within the specific project Terms of Reference or unless written approval has been received from Niagara Region. Water projects must comply with all guidelines in both Sections A (General) and B (Water) while wastewater projects must comply with all guidelines in both Section A (General) and C (Wastewater).

This document does not supersede or replace any effective legislation standards and regulations governing the design of water and wastewater infrastructure. In case of any conflict with this Standard and any effective legislation standards and regulations, the most stringent requirement will apply.

A.2 Reference Documents

This document is intended to be read in conjunction with the latest version of the following Niagara Region documents:

1. [Niagara Region Water and Wastewater Master Servicing Plan](#)
2. *Niagara Region Water and Wastewater Security Technical Specifications*
3. *Regional Municipality of Niagara Automation Standards Manuals*
4. *Niagara Region Biosolids Management Master Plan*
5. *Niagara Region Water and Wastewater Services Commissioning Guideline*
6. [Niagara Peninsula CAD Standards](#)
7. [Niagara Peninsula Standard Contract Documents \(NPSCD\)](#)
8. *Niagara Region Water and Wastewater Approved Product and Equipment List (APEL)*
9. *Niagara Region Water and Wastewater Operations Manual Template*
10. *Niagara Region Water Chemical System Design Standard*
11. *Niagara Region Wastewater Chemical System Design Standard*
12. *Niagara Region Filter Media Replacement Specification*
13. *Niagara Region Water and Wastewater Services Working at Heights Procedure*
14. *Niagara Region's Standard Operating Procedure for Turbidity*
15. *Niagara Region's Quality Management System*

16. *Niagara Region Policy for Lettering on Steel Water Storage Tanks and Stand Pipes*

17. *Niagara Region Sewer Use Bylaw*

A.3 Designer Responsibilities

Designs of water and wastewater infrastructure shall comply with the latest version of all applicable acts, codes, bylaws, regulations, guidelines and standards including Niagara Region's *Drinking Water Quality Management System* and *Wastewater Quality Management System*.

All sections of this Project Design Manual (PDM) are related, and each section of the PDM is not necessarily complete in itself. The Designer shall read each section, in conjunction with all other sections, to ensure a complete design, and that all project requirements are met.

All designs are to be completed using the metric system. If imperial units are used for technical reasons, the metric equivalent shall also be labelled next to it.

A.3.1 Approvals and Permits

The designer will be responsible for the preparation of all applicable approval/permit applications necessary to construct the facility (including initial submission, follow-up and securing of all approvals and permits).

A.3.2 Non-Compliance with Design Manual

If the designer deems that deviation from this manual is in the best interest of the project, then the designer is required to make a formal request to Niagara Region's Project Manager with a memorandum identifying the deviations with an explanation of the benefits to the project.

A.3.3 Level of Service and Backup (Redundant) Equipment

The level of redundancy for process and equipment shall be in compliance with regulatory objectives, generally with sufficient backup devices to be able to meet peak instantaneous demand following failure (or maintenance) of one largest capacity unit. The designer shall ensure that the flow to any treatment process unit out-of-service can be routed to remaining units in service with minimum impact on their performance.

A.3.4 Risk Assessment

The designer is expected to complete and maintain a risk assessment in the form of a risk register which includes, but is not limited to, the following information.

1. List of all potential risks with unique identification number
2. Date risk was identified
3. Description of risk
4. Type of risk (safety, environmental, financial, social, contractual, technical, schedule, liability, etc.)

5. Stage at which project risk may occur
6. Evaluation of the probability/ likelihood and impact/ consequence of the risk
7. Ranking of the risks
8. Description of potential mitigation measures (accept, avoid, transfer, reduce)
9. Final decisions and status of risk
10. The risk analysis shall address the following questions.
 - a) What is the criticality of each asset that is to be taken out of service?
 - b) Is the facility to remain in operation while the upgrades are taking place?
 - c) What contingency plans will be implemented to mitigate the risks?
 - d) What costs are associated with each contingency plan?

A risk analysis meeting involving all potentially affected parties shall be required. The designer shall determine if the area municipality(ies) can be considered to be potentially affected party(ies).

A.3.5 Hazard and Operability Review

The designer is required to complete the Hazard and Operability Review (HAZOP), which is a systematic, critical examination of the process and engineering design of the facility/ plant. The designer will audit this review through workshops at specified stages of the project. The intent of the review is to assess the potential hazard of the failure of individual equipment and the consequential effects on the facility as a whole and its potential for negative impact on the environment. The HAZOP review will identify potential hazards associated with the operation of the facility/ plant and will provide recommendations to be incorporated into the design reports relating to the following.

1. Finished water quality
2. Effluent water quality
3. Hydraulic overload
4. Emergency overflows
5. Module by-pass
6. Equipment hazards
7. Equipment failure hazards
8. Odour hazards
9. Health and safety review
10. High/low nutrient load
11. Spills to the environment

12. Specific hazards for elevated tanks

A.3.6 Health and Safety

In addition to current health and safety guidelines and regulations, Niagara Region has the following requirements for all water and wastewater projects:

1. Roofing designs must include requirements for anchors tie-offs, or other approved means of fall restraint and fall arrest.
2. A general requirement to design facilities to eliminate confined spaces. Where the design cannot eliminate all confined spaces, all reasonable efforts must be made to reduce the quantity of confined spaces and hazards within any confined space. The space must be designed for ease of ingress, prompt egress, and have appropriate fall arrest and retrieval safeguards.
3. To allow Niagara Region to update its Confined Space Entry database accordingly.
4. Under the Health & Safety Review requirement, Niagara Region's Project Manager will coordinate with the Water/Wastewater Health & Safety Coordinator who will be involved in the design review process.
5. Access hatches to be insulated, watertight complete with recessed hatch padlock, lift assist cylinder with locking mechanism designed with secondary fall protection grating.
6. Designs must address travel restriction, fall restriction and fall arrest for work that may be required while working at heights.
7. Designs must identify how Niagara Region's operation and maintenance staff will be protected.
8. Hazardous gas monitoring in potentially hazardous areas shall be conducted using personal, portable devices.
9. Electrical safety considerations must be made according to all applicable acts, codes, standards, and guidelines.
10. Adequate designs must integrate lock-out/tag-out requirements for all sources of energy. The location of disconnects shall be in the most logically safe location for access and operation.
11. Designs must mitigate excessive noise to the environment and to workers.
12. Where possible, designs must identify atmospheric hazards, assess these hazards with respect to incompatible emissions, and provide adequate ventilation.
13. Emergency eyewash and deluge shower stations shall be provided in the vicinity of the chemical storage areas or other potential exposure risks. The water supply should be tepid water and be compliant with American National Standards Institute (ANSI) Standard Z358.1. The water supply and eyewash/ shower facilities shall be protected from freezing.

14. With respect to the area and function of the environment, designs must provide for adequate illumination for worker safety.
15. A Designated Substance Survey (DSS) must be conducted during the design phase.
16. Prior to final commissioning, conduct Pre-Start Health and Safety Reviews as required as per Ontario regulations.

A.3.7 Security

All water and wastewater facilities shall be designed to comply with the requirements of the Niagara Region Water and Wastewater Security Technical Specifications.

1. This shall apply to perimeter fences and gates, site property and access roads, doors, windows, access hatches, ventilation louvers, overflows and outfall sewers.
2. Site specific considerations from the local municipality must also be followed.

A.3.8 Tender Documents

All tenders for construction will be based on the *NPSCD*. The front end of the tender document will be prepared using the latest version of Niagara Region's standard template at the time of preparation. No deviations from the standard template will be permitted without the express approval of the Project Manager and Procurement Department. In all instances the Tender Documents will contain all relevant sections and specifications and not refer to outside or third party documents.

For linear projects, Special Provisions – Contract Items (SPCI) in the *NPSCD* shall be used. Where there is no specific item specification in the SPCI, or a specification requires modification, the designer will provide the required specification, or modification, in the Special Provisions – Contract Items Supplementary (SPCIS) section.

For facility projects, the *Canadian National Master Construction Specification (NMS)* (16 Divisions) are to be used.

For facility and linear projects, a combination of SPCI, SPCIS and NMS are to be used.

The designer shall prepare a draft commissioning plan as per the *Niagara Region Water and Wastewater Services Commissioning Guidelines*, which shall be included in the tender documents.

A.3.9 Operations Manual

The Operations Manual is a written description that provides a basis for operator training, highlighting the operation of the facility and describing the function of the facility and all associated processes. The designer shall prepare, or update, the Operations Manual in accordance with the latest version of the *Niagara Region Water and Wastewater Operations Manual template*.

A.3.10 Energy Efficient Design

The design of any new system, building, or unit process should consider alternatives to reduce energy costs while still meeting overall objectives for operations, performance and

longevity. Wherever practical and cost-effective, these ideas should be incorporated into the design.

The designer will include an energy audit benchmark for the consumption of existing equipment and unit processes to evaluate potential energy savings of an upgrade or retrofit.

The designer will select equipment and vendors that meet the performance specifications while having lower energy consumption requirements.

Refer to Section C for energy efficient design approaches pertaining specifically to wastewater treatment plants.

A.4 Design Disciplines

A.4.1 General

The main components of facilities shall be designed for the following minimum service life targets.

Item Description	Minimum Service Life(years)
Structures	100 (post disaster)
Piping and Fittings	>80
Pumps	25
Valves	25
Paints and Coating Systems	25
Electrical	15
Controls and SCADA	10

Niagara Region Integrated Services Group are to be included in the review of shop drawings during the construction phase for electrical, control and SCADA equipment.

A.4.2 Civil

A.4.2.1 Design Vision

Buried infrastructure shall efficiently convey water and wastewater, and its installation and maintenance shall have minimal long-term negative impacts on the existing landscape once restoration is complete.

A.4.2.2 Design Basis

Buried infrastructure shall be designed to meet *Ministry of the Environment Conservation and Parks (MECP) Guidelines*, to be structurally sound subject to all dead and live loading, to be capable of withstanding all thrust forces and surge and transient pressures, burial depths, buoyancy and to minimize maintenance requirements. Buried infrastructure shall consist of suitable materials as specified in this manual.

A.4.2.3 System Layout

Buried infrastructure shall be located within the public right-of-way and shall not conflict with area municipality infrastructure or with buried utilities.

Buried infrastructure on Niagara Region property shall be located so as not to hinder future expansion of facility operations, shall be accessible for repairs or maintenance when required and shall not conflict with existing buried infrastructure.

All buried chemical feed lines in the public right-of-way and at facilities are to be installed in carrier conduits with tracer wire.

A.4.2.4 Facility Layout

The designer shall comply with the following requirements when designing new, expanding or upgrading treatment plants and remote facilities.

1. Provide adequate space between existing and new equipment for operation and maintenance requirements.
2. Ensure that installed valves and equipment can be easily removed. Give consideration to valve and equipment support during removal by means of crane or engineered lifting points.
3. Provide flexibility in facility design to accommodate future possible changes in operation.
4. Ensure that the facility is designed to allow for future expansion works.
5. Give consideration to full site build-out conditions.
6. Give consideration to accommodating future capacity increases within the life expectancy of the asset.
7. Avoid confined spaces where possible.
8. Provide reasonable access to all areas of the site.
9. Provide low maintenance landscaping. Give consideration to sustainable vegetation, grasses, native plantings where required.
10. Provide safe and effective site grading.
11. Bollards must be included to protect equipment, generators, building or other critical site components.
12. Where appropriate, give consideration to permeable pavement systems for driveways and other asphalt surfaces based on traffic loading and proposed usage.
13. Where appropriate, give consideration to visitor and accessibility parking spaces.

A.4.2.5 Valve Chambers

The designer shall take the following requirements for valve chambers into consideration.

1. Chamber size shall be selected to adequately accommodate all pipe, valves and equipment
 - a) Provide minimum clearances of 1.0m on both sides of the pipe. As reviewed on a case-by-case basis, the Region may permit a reduction of the clearance requirement to 0.6m on one side of the pipe opposite any actuators or pipe outlets provided that the reduced clearance does not encumber maintenance or operation activities.
 - b) Provide minimum clearance of 0.3m to maximum 0.6m below pipe to allow sufficient space for servicing and/ or removal of valves and appurtenances when required.
 - c) Valve chambers shall be designed with minimum head room of 2.1m.
 - d) Flanges/couplings shall be a minimum of 300mm away from the chamber wall.
2. The preference is to have valve chambers installed in boulevard areas with exposed chamber flat caps and highway load rated watertight insulated aluminum hatches. Valve chambers installed inside of vehicular traffic areas or within the shoulder area are to be buried flat caps with frame and cover as per OPSD 402.030.
3. Valve chambers located in gravel shoulders shall be provided with a paved area sufficient for parking of one vehicle. Size of vehicle to be determined as appropriate for the need of the chamber.
4. Adjustment units (50mm thick) (min 1, max 3), as per OPS, shall be provided for grade adjustment(s) for chambers on roadway.
5. All concrete valve chambers shall be provided with adequate thrust restraints, approved waterproofing on complete exterior, sealed joints, and must be insulated from the ground surface to below the frost depth.
6. Chambers are to be insulated with 50mm thick rigid high-density closed cell polystyrene insulation. Buried chambers will be insulated on exterior of chamber roof and walls to a minimum 1.2m below grade (or below frost levels). Chambers with exposed roofs are to be insulated on the exterior walls below grade to a minimum depth of 1.2m (or below frost levels) and on inside roof and 600mm down walls supported with pressure treated plywood.
7. Waterproof entire exterior of chamber using an SBS modified bitumen membrane or a three-part petrolatum tape meeting ISO 9001 Standards. Waterproofing material shall be sealed to the concrete surface to ensure no air pockets or other spaces that may allow water infiltration. Waterproofing material shall be applied in accordance with the manufacturer's instructions.
8. Chambers shall include a sump located in the vicinity of the access hatch.
9. All chambers containing electrical equipment shall be provided with a gravity drain complete with trap guard type backflow system (preferred) or float controlled sump pump which shall discharge to a sewer/wetwell where possible. If discharge to a

sewer is not possible then flow will be discharged to the surface, and directed away from the structure. All sump pumps shall be intrinsically safe.

10. All access hatch self-draining trough drains to be piped to the exterior (preferred) or to chamber sump.
11. Isolation valves shall be provided with stainless steel extension stems complete with stem supports at maximum 3m intervals
12. Victaulic couplings shall be considered for valve and equipment removal. Spool pieces shall be adequately sized to provide sufficient separation between the coupling and the adjacent valve/equipment.
 - a) 0-300mm diameter: Style 89
 - b) 350mm-600mm diameter: Style W89
 - c) 650mm-1250mm diameter: Style W07
13. Consultant shall design the restrained flexible coupling system outside of the valve chamber to transition from stainless steel to the forcemain/watermain in accordance with the respective soil conditions. Double restrained flexible couplings shall be considered in areas where there is greater risk of differential settlement.

A.4.2.6 Pipe Bedding and Trench Backfill

1. Watermains, sewers, forcemains and other buried linear piping shall be provided with a pipe embedment (bedding and cover) as per the Ontario Provincial Standard Drawings. Minimum depth of bedding shall be 200mm.
2. Bedding and cover material shall be Granular 'A' crushed limestone compacted to 100% Standard Proctor Maximum Dry Density (SPMDD).
3. The type of trench backfill material above the pipe cover material will usually be determined by the location of the linear piping within the right-of-way (ROW). Approved granular backfill compacted to 100% SPMDD shall be used for trench backfill within all road bases and driveways unless the local municipality and Region permits recycled granular or native material compacted to 98% SPMDD for trench backfill between the pipe cover and road base. Native material compacted to 95% SPMDD to be used for trench backfill above the pipe cover in boulevard areas.

A.4.2.7 Tracer Wire

1. All buried linear and facility piping including: watermains; forcemains; hydrant laterals; service laterals; chemical feed lines; and all other buried facility piping shall be provided with tracer wire as per the tracer wire requirements contained in this Manual.
2. Tracer wire shall not be installed through chambers, but must be placed around the outside ensuring continuity.
3. Tracer wire is not required on gravity storm and sanitary sewers.

4. Tracer wire shall be #10 AWG Solid steel core soft drawn high strength tracer wire as supplied by Copperhead or approved equal.
5. For directional drilling, auguring or boring installations, three #12 AWG Solid Extra High Strength Copper Clad Steel Conductor (EHS-CCS) shall be installed with the pipe and connected to the tracer wire at both ends
6. Tracer wire shall be extended up to grade in a PVC conduit to dedicated tracer wire test stations.
7. Tracer wire test stations are to be no more than 300m apart, and the location of all tracer wire test stations shall be indicated on all engineering drawings.
8. Tracer wire test stations shall be located at the property line.

A.4.3 Architectural

A.4.3.1 Design Vision

Buildings for water and wastewater facilities shall be designed to match aesthetic requirements of the surrounding neighbourhood and meet the following requirements.

1. Have minimal maintenance requirements.
2. Complement the surrounding environment.
3. Provide access that meets the requirements of the Accessibility for Ontarians with Disabilities Act (AODA) where appropriate.
4. Be designed to post-disaster standards.
5. Ensure that all openings in the exterior walls are equipped with insect screens and vandal proof louvers.

A.4.3.2 Roofing Design

Design roofs with the following considerations:

1. Sloped roofs only.
2. Give preference to metal roofs over asphalt shingles.
3. All metal roofs shall be provided with lightning rods and grounding.
4. Provide snow guards, eaves and downspouts.
5. Downspouts to be located and oriented such that water is directed away from the structure by the shortest path possible.

A.4.3.3 Windows and Doors

Windows and doors must comply with Niagara Region Water and Wastewater Security Technical Specifications.

A.4.3.4 Wall Finishes

Interior and exterior walls shall be provided with the following finishes:

1. All interior walls shall be architecturally coordinated to provide a level of finish selected for the use or service intended. Additional consideration shall be given to humid environments typically encountered within water and wastewater facilities.
2. Painting for aesthetic purposes shall be limited to areas intended for human occupancy.
3. For bathrooms and washrooms, ceramic tile finishes will be provided on walls.
4. Graffiti resistant materials or graffiti resistant coatings shall be considered for all exterior exposed walls and/or surfaces not secured by a perimeter fence.

A.4.3.5 Floor Finishes

The floor shall be finished in accordance with the following criteria:

1. Office, laboratories, computer control rooms, lunchrooms and other general-use rooms shall be provided with non-slip ceramic tile floor finishes.
2. Concrete floors within process areas shall be provided with a slip resistant epoxy finish.
3. All other concrete floors shall be provided with non-coloured floor concrete hardener complete with floor sealer.

A.4.3.6 Ladders, Handrails and Landings

1. All ladders, handrails and landings, shall be aluminum 6063-T6 (preferred) or stainless steel Type 316L (based on location of installation unless otherwise stated herein).
2. Acceptability of NSF-61 approved fiberglass-reinforced plastic (FRP) will be reviewed on a case by case basis. FRP will only be acceptable indoors but not in areas in direct contact with sewage or hydrogen sulfide.

3. Landscaping

Landscaping shall be designed to minimize maintenance requirements and to meet the Municipality Site Plan Approval requirements. Preference shall be given to native plant or tree species in Ontario, which require minimal watering. Xeriscaping shall be considered in landscaping design where applicable.

A.4.3.7 Fencing, Gates and Signs

For the requirements pertaining to the facility fencing, gates and signs, refer to Niagara Region Water and Wastewater Security Technical Specifications.

A.4.3.8 Lighting

See Electrical Section A.4.8 below.

A.4.4 Structural

A.4.4.1 Design Vision

The designer is to construct all structures with the overall lowest life cycle cost. All structures shall to be designed to post-disaster standards.

A.4.4.2 Basis of Design

Complete structural designs in accordance with the following criteria:

1. All below grade structures shall be constructed with reinforced concrete complete with water stops and Zemdren (Type II) formwork liner for all exposed surfaces.
2. Structures shall be insulated from the surface to below the frost level (minimum 2.0) and buried structures waterproofed.
3. All miscellaneous metals within water structures shall be stainless steel 316L and wastewater structures shall be type 304/304L stainless steel. Fiberglass reinforced plastic may be substituted for stainless steel where reviewed on a case by case basis and accepted by the Region.
4. All materials in contact with potable water shall be American National Standards Institute / National Sanitation Foundation – 61 (ANSI/NSF-61) certified.
5. Stairway access into below grade structures is preferred. Where stairway access is not possible, access hatches and ladders shall be provided.
6. All water retaining structures shall contain a minimum of two independent cells. Each cell must be capable of being isolated for inspection and maintenance purposes without affecting the operation of the other cell(s). Each cell shall be provided with a minimum of two entry/exit points.
7. Concrete water retaining structures shall be constructed of high-performance low-shrinkage concrete. Shrinkage bar testing shall be required.
8. In addition to the Zemdren liner applied to the exposed face in direct contact with water or wastewater, a crystalline admixture shall be considered to improve the long term durability and performance of the concrete structure.
9. Coatings on steel retaining structures shall be designed to withstand normal operating conditions including corrosive and potentially high-chlorine environments. Minimum expected service life of coating shall be 25 years.
10. All expansion joint and caulking material must be protected from exposure to chlorine both during normal operation and during the disinfection process.
11. All ground level, partially buried and underground water retaining structures top shall be a minimum of 200mm above the 100 year flood or the highest flood on record.
12. The area surrounding a ground level or below grade water retaining structure shall be graded to be free of standing water for a minimum distance of 15 metres.
13. Where a water retaining structure base slab is below the pre-construction original finished grade it is preferable to install the base slab above the ground water table.
 - a) Consideration must be given to fluctuations in the water table, therefore, a sub-structure drainage layer of granular material drained to atmosphere or a gravity drained storm sewer is required.

- b) Maintenance hole access shall be provided at changes in directions along the drainage sewer for access and clean outs.
 - c) In the case where a gravity drainage solution is not possible, a pump dewatering system shall be provided.
14. In the event that the groundwater is expected to be unavoidable, hold down anchors shall be considered.
- a) Pressure relieve valves shall not be used.
 - b) It is the expectation of Niagara Region that a comprehensive plan which addresses buoyancy concerns and/or groundwater removal shall be developed by the designer.
 - c) Such plans shall include comprehensive operational and logistical procedures for draining the water retaining structure for inspection purposes while being mindful of groundwater conditions adjacent to the structure.
15. The designer shall provide a minimum separation of 15 metres between potable water retaining structures and sewers, drains, septic tanks and tile fields.
16. Drains, sewers and other piping located within 15 metres shall be constructed of piping material with a pressure rating suitable for a pressure test of at least 350 kPa. Such pressure tests will have zero leakage.
17. Mud slabs shall be considered for wet excavations to create a temporary level and dry base.

A.4.5 Process Mechanical

A.4.5.1 Design Vision

Mechanical systems shall be designed to provide ease of operation and maintenance with an emphasis on efficiency and energy conservation.

For each process train, either have dedicated duty/standby equipment or if redundant equipment must be shared due to space constraints or costs, then ensure actuated valves are in-place to allow the equipment to be placed in duty via SCADA – no manual valves to allow the redundant equipment to operate.

A.4.5.2 Equipment Tagging

1. Flat surfaces shall be provided with lamacoid nameplates.
2. Valves and equipment having curved surfaces shall be supplied with stainless steel engraved tags complete with stainless steel chain affixed to the equipment.
3. Equipment tagging shall follow the device position labelling in the Niagara Region Automation Standards

A.4.5.3 Piping

1. The designer shall ensure that all process piping can withstand all expected internal and external pressures, loads, thrust forces and transient pressures.
2. All exposed process pressure piping in water facilities shall be, at a minimum, North American type 316L schedule 10S stainless steel and type 304/304L or 316L schedule 10S stainless steel in wastewater facilities.
3. All piping in contact with potable water shall be ANSI/NSF-61 certified.
4. All process mechanical piping shall be provided with colour-coded labels to comply with the latest edition of the *ANSI/ASME A13.1 Pipe Labeling Requirements* per the following table.

Label Background Colour	Letter Colour	System	Max Label Spacing
Dark Blue	White	Untreated Water	3 m
Light Blue	White	Treated (potable) Water	3 m
Light Blue	White	Domestic Hot Water	3 m
Light Blue	White	Chilled Water	3 m
Light Brown	White	Backwash Waste	3 m
Light Brown	White	Settled Backwash	3 m
Dark Brown	White	Sludge	3 m
Dark Brown	White	Sanitary Waste	3 m
Dark Brown	White	Scum	3 m
Dark Brown	White	Supernatant	3 m
Dark Brown	White	Filtrate (San)	3 m
Light Grey	White	Storm Drainage	3 m
Dark Green	White	Effluent Water	3 m
Yellow	Black	Propane Gas	3 m
Yellow	Black	Natural Gas	3 m
Yellow	Black	Hydraulic Oil	3 m
Yellow	Black	Fuel Oil	3 m
Yellow	Black	Digester Gas	3 m

Label Background Colour	Letter Colour	System	Max Label Spacing
Red	White	Fire Protection	3 m
Orange	Black	Boiler Feed	3 m
Orange	Black	Boiler Blow-off	3 m
Orange	Black	Acid Drain	3 m
Orange	Black	Compressed Air > 670 Kpa	3 m
Orange	Black	High Temperature Water	3 m
Orange	Black	Low Pressure Steam	3 m
Orange	Black	High Pressure Steam	3 m
Orange	Black	Low Pressure Condensate	3 m
Orange	Black	High Pressure Condensate	3 m
Green	White	Tempered Domestic Water	3 m
Green	White	Condenser Water	3 m
Green	White	Hot Water Heating	3 m
Green	White	Plumbing Vent	3 m
Green	White	Compressed Air	3 m
Green	White	Instrument Air	3 m
Green	White	Vacuum	3 m
Light Green	White	Aluminum Sulphate	3 m
Light Green	Orange	Ferric Chloride	3 m
Yellow	Red	Sodium Hypochlorite	3 m
Yellow	White	Chlorine Gas	3 m
Yellow	Orange	Chlorine Dioxide	3 m
White	Orange	Lime	3 m
White	Orange	Sodium Bisulfate	3 m
White	Orange	Sodium Carbonate	3 m

Label Background Colour	Letter Colour	System	Max Label Spacing
White	Orange	Sodium Bicarbonate	3 m
Purple	White	Potassium Permanganate	3 m

5. Colour-coded arrows shall be provided indicating the direction of flow.
6. Pipe sweating shall be controlled with ventilation, dehumidification and, if required, insulation.
7. Only standard pipe sizes will be used.
8. Adequate supports for all piping shall be designed and shown on drawings with appropriate details.
9. Long radius elbows are preferred.
10. Sample taps shall be installed on all suction and discharge headers.

A.4.5.4 Valves

1. Main process valves shall be stainless steel or cast/ductile iron complete with internal and external fusion bonded epoxy (FBE) coating, or two part liquid epoxy coating.
2. Valves shall comply with *American Water Works Association (AWWA) Specifications and Standards*.
3. All valves in contact with potable water shall be ANSI/NSF-61 certified.
4. All valves shall be of the correct type for the transmitted fluid, pressure expected and the valve use (ie. shut-off, modulating, etc.).
5. Drain valves should be considered for significant low points and air relief valves should be considered at significant high points.
6. Valves and valve operators shall be oriented to meet the following requirements.
 - a) Ease of operation
 - b) Limited interference with structures and with any other equipment or piping
 - c) Space allowance requirement for maintenance and disassembly
 - d) Valves mounted higher than 2 m shall be provided with a chain operator.
7. Redundant knife gate valves shall be considered downstream of butterfly valves in critical and modulating valve locations.
8. Valve systems associated with water pumps with more than 100 mm of discharge shall consist of a suction isolation butterfly valve, discharge check valve, motorized butterfly valve and isolation knife gate valve prior to connection to the discharge header.

- a) Ball valves, 50 mm in size, shall be located at the top and bottom of the suction and discharge piping.
9. In potable water facilities, non-buried valve type and materials shall be as follows:
- a) Valves less than 50 mm shall be stainless steel ball valves.
 - b) Valves 75 mm to 300 mm shall be rising stem knife gate valves.
 - c) Valves 300mm and greater shall be butterfly valves except for valves whose purpose is to isolate a butterfly valve. These may be knife gate valves. Seat on body style butterfly valves are preferred but seat on disc can be used in frequently actuated valve locations.
 - d) Check valves shall be cast/ductile iron fusion bonded epoxy (inside and out) or two part liquid epoxy complete with stainless steel hardware.
 - e) Air release valves shall be stainless steel or cast iron fusion bonded epoxy (inside and out) or two part liquid epoxy complete with stainless steel hardware and an anti-slam device. The designer shall provide a flood protection double check valve on a vent within chambers. Only air release valves associated with water systems may be considered in a direct-bury application.
 - f) Globe style pressure relief, surge or pressure control valves shall be cast iron fusion bonded epoxy (inside and out) or two part liquid epoxy with stainless steel pilots and stainless steel sensing lines complete with anti-cavity trim as required.
 - g) Sluice gates shall be fabricated from 316L stainless steel. Operators shall be located at ground level.
10. For water transmission systems, valve type and materials shall be as follows:
- a) Gate valves conforming to AWWA C509 or AWWA C515 shall be provided on transmission mains up to and including 300 mm diameter.
 - b) Seat on body style butterfly valves conforming to AWWA C504 shall be provided on transmission mains 300 mm in diameter and larger.
 - c) All butterfly valves shall be housed in approved, adequately designed watertight chambers unless specified otherwise.
 - d) All valves require valve boxes and are to open left (counter clockwise) and shall have a 50 mm square standard AWWA operating nut.
 - e) Where possible, valves shall be located outside of the travelled portion of the road and intersections.
11. In wastewater facilities, non-buried valve type and materials shall be as follows:
- a) Valves 50 mm and less shall be stainless steel ball valves.
 - b) Valves 75 mm and larger shall be stainless steel knife gate.

- c) Knife gate valves shall be selected to meet the anticipated maximum design pressure for each side (i.e. uni-directional vs bi-directional). Specifications for bi-directional knife gate valves shall identify the anticipated maximum design pressure for each side of the valve. Preference is that knife gate valves to be installed vertically, otherwise be equipped with gate guides.
 - d) Check valves shall be cast/ductile iron fusion bonded epoxy (inside and out) or two part liquid epoxy complete with stainless steel hardware.
 - e) Air release valves shall be stainless steel or cast iron fusion bonded epoxy (inside and out) or two part liquid epoxy with stainless steel hardware. Flushing ports must be provided to clean the air valve. Direct buried air release valves are not permitted on wastewater systems.
 - f) Sluice gates shall be fabricated from 316L stainless steel. Operators shall be located at ground level.
12. For wastewater forcemains, all direct bury valves shall be gate (preferred) or plug valves.
13. Piping, valves and equipment shall be properly supported with concrete or stainless steel supports.
14. Victaulic couplings or flange adapters shall be considered near all valves and equipment for maintenance or removal purposes.

A.4.5.5 Pumps and Motors

- 1. All equipment and motors shall be supplied with corrosion resistant metal nameplates fitted securely in a location which can be easily read.
- 2. Pumps and other rotating equipment shall be provided with bearings selected on the basis of a B-10 life expectancy as defined by the Anti-Friction Bearing Manufacturers Association at rated conditions of service of at least 150,000 working hours. Conventional lubricating points shall be specified.
- 3. Bearings for electric motors shall be constructed of double seal bearings.
- 4. All pumps or equipment in a process system should be of equal size to promote proper redundancy and flexibility in operating any piece of equipment as duty to ensure even usage of all pieces throughout the process system.
- 5. Hardwired interlocks are to be provided to stop the equipment or prevent the equipment from starting for operational or safety purposes as per the Niagara Region Automation Standards.

A.4.5.6 Equipment Operating Characteristics

- 1. All pumps furnished shall operate satisfactorily without excessive wear, excessive lubrication or undue attention required by the operating staff. All rotating parts shall be in true dynamic balance and operate without vibration caused by mechanical defects,

faulty design or misalignment of parts. The designer shall take these factors into consideration and design a system that is within acceptable tolerances.

2. To confirm that the vibration level is within the specified limit the designer shall ensure that vibration analysis for all pumps 75 KW (100 HP) and larger and other critical pieces of equipment is carried out by a third party consultant using vibration sensors as part of the startup procedure of the equipment and also at the end of the three month operating period. The results of the vibration analysis at the startup procedure shall be included in the Contractor-supplied Equipment Maintenance Manual.

A.4.5.7 Equipment Acceptance Testing

1. Pumps shall be acceptance-tested according to Hydraulic Institute Guidelines Level "A" tolerances as per the following.
 - a) Pumps less than 50 hp (37 kW) are to be supplied with a standard performance curve certified by a factory trained technician or a professional engineer.
 - b) For pumps 50 to 300 hp (37 to 224 kW), a certified factory acceptance test (FAT) is required including sign-off by a professional engineer.
 - c) For pumps greater than 300 hp (224 kW), a witnessed FAT is preferred including sign-off by a licensed professional engineer.
2. FATs shall be conducted prior to releasing such equipment for delivery to site. FATs shall be conducted with the actual motor to be used rather than a shop motor.

A.4.5.8 Equipment Guards

1. Equipment guards shall be provided for all rotating components, couplings, belts, chain drives and extended shafts.
2. Equipment guards shall be hot-dip galvanized steel painted yellow or stainless steel.
3. All equipment shall meet the requirements of the Ontario Health and Safety Act.

A.4.5.9 Equipment Maintenance Requirements

1. The designer shall provide a minimum of 1 m of clear space around all equipment for maintenance work or more as directed by the equipment supplier.
2. Equipment that requires removal for maintenance shall be provided with electrical and mechanical isolation devices to allow for removal without interfering with the operation of the process or facility.
3. In designing the layout of the equipment, the designer shall make provisions for its removal including providing a suitable lifting mechanism.
4. All equipment shall be mounted on a concrete pad with a minimum height of 100mm.

A.4.6 Heating, Venting and Air Conditioning (HVAC)

A.4.6.1 Design Vision

1. HVAC systems shall provide the necessary environmental controls to maximize the performance of the equipment in the facility, while providing comfort heating and cooling to occupants. As most facilities are largely unoccupied, the environment required for optimal equipment performance typically takes precedence.
2. Areas designed for continuous occupancy such as offices, control rooms, locker rooms, lunch rooms/kitchens shall have dehumidification capability.
3. Provide heating, ventilation and air conditioning equipment that meet energy efficiency requirements.
 - a) Overly complicated schemes with limited efficiency gains shall be avoided.
 - b) Heat Recovery and Energy Recovery systems shall only be included in a design where they will provide a good return on investment, have reasonable life expectancy, and require minimal maintenance.
4. Preference shall be given to the use of natural gas heating in place of electric heat.
5. Design can consider zone control and separate systems depending on classification of the area.

A.4.6.2 Equipment Tagging

1. Flat surfaces shall be provided with lamacoid nameplates.
2. Equipment having curved surfaces shall be supplied with stainless steel engraved tags complete with stainless steel chain affixed to the equipment.
3. Equipment tagging shall follow the device position labelling in the Niagara Region Automation Standards

A.4.6.3 Design Features

1. Under no circumstances shall fans be relied on to declassify newly constructed hazardous spaces on a continuous basis.
2. The National Fire Protection Association 820 (NFPA 820) guidelines shall be followed if older hazardous spaces must be de-rated by ventilation.
3. In a hazardous space, all permanent equipment shall be rated for the unventilated environment.
4. Ventilation shall be available when the hazardous space is occupied as follows.
 - a) Air handling unit (AHU) changeable from 3 Air Changes per hour (ACPH) to 6 ACPH controlled via a door contact switch separate from the security system.
 - b) Once the switch has been tripped the AHU will change from 3 to 6 ACPH.

- c) Motion sensors will be located within the classified area to maintain operation at 6 ACPH.
 - d) If no motion is sensed for a period of time (i.e. 30 to 60 min) the AHU will revert to 3 ACPH. A local audible alarm will pulse on and off for 30 seconds (configurable) prior to reverting back to 3 ACPH to alert current stationary occupants of the transition.
 - e) A fault in the AHU that does not allow the switch from 3 to 6 ACPH, or back to 3 ACPH, will activate a local audible alarm.
 - f) The alarm will be acknowledged locally via a button, but a fault indicator will remain on until the fault is corrected. If the alarm is not acknowledged, the local audible alarm will automatically shut off after 5 to 10 minutes (configurable) but the local fault indicator (pilot light) will remain active.
 - g) Faults within the AHU will be monitored locally and through SCADA at the receiving WWTP.
 - h) Ability for "LOCAL Control" via manual override to activate the mechanical ventilation from 3 to 6 ACPH shall be provided.
5. The heating and cooling requirements for each zone shall be achieved by a dedicated control unit linked to the master control system. However, the zone control unit must be capable of being overridden manually from the HVAC master control system.
6. Design shall consider the environment of specific areas and consider dehumidification if required for the environment and to protect equipment.

A.4.7 Standby Power

A.4.7.1 Design Vision

Sufficient backup power must be provided at all critical facilities to maintain a full level of service for at least two days (48 hours) following a loss of grid power. Preference is for a packaged, stand-alone system consisting of an air-cooled generator in a self-contained sound attenuating skin tight outdoor enclosure.

Natural gas powered generators are preferred over diesel however both fuel types shall be evaluated during design to recommend the best suited for the specific application.

Standby power shall be provided to the following key facilities:

1. Wastewater Treatment Plants, Sewage Pumping Stations and Remote Facilities.
 - a) All facility essential loads must be capable of being fed from the plant's standby generator(s) at peak hour flow conditions in order to meet Environmental Compliance Approval (ECA) requirements.
2. Water Treatment Plants and Remote Facilities.
 - a) All facility essential loads must be capable of being fed from the plant's standby generator(s) to enable the water treatment plant to meet maximum day demand.

3. Chlorine Booster Stations. To be reviewed at the pre-design stage of the project and subject to the final decision of the design team.
 - a) All essential equipment (i.e. Pumps, PLC, analyzers, flowmeter, heater(s) and lights) are to be provided with standby power.
4. Booster Pumping Station and Remote Storage Facilities including Elevated Water Tanks and Reservoirs.
 - a) All essential equipment including Pumps, PLC, analyzers, flowmeter, navigation beacons, heater(s) and lights are to be provided with standby power to meet maximum day demand plus fire flow.

A.4.7.2 Design Features

Emergency standby power systems shall be designed with the following features:

1. Emergency standby power systems shall be registered through the MECP Environmental Activity and Sector Registry (EASR) system and shall meet requirements regarding air and noise levels as per Part III of Ontario Regulation 346/12.
2. Grounding shall be installed around the generator.
3. Radiator air cooled engines only.
4. Where a diesel generator is specified, the fuel system shall consist of a double walled tank with minimum storage capacity suitable for 48-hour operation at a full generator load starting at 75% full tank. A fuel level indicating transmitter wired to the programmable logic controller (PLC), a low and high float switch, vent whistle and a fuel leakage alarm must be provided. Preference is to have the fuel tank located under the generator.
5. Emergency standby power systems to meet the requirements of Code B139.10. Essential variances for equipment not meeting the requirements of the B139.ON code must be obtained and posted near generator to avoid non-compliance during future inspections.
6. The ventilation system shall be complete with fans, dampers, etc. to meet the required air volume for engine combustion and ventilation requirements.
 - a) The engine ventilation system shall be designed to operate with and without local utility power and also for testing of the various modes of operating conditions.
 - b) Combustion Air Ventilation dampers must be fully open before the diesel engine is permitted to start. Obtain variance from the Technical Standards and Safety Authority (TSSA) if the designer and owner choose not to meet this requirement at critical stations where it is necessary for the generator to start even if the damper fails to open.
 - c) Dampers shall “fail safe” in the open position.

- d) All ventilators shall be vented to the exterior of the enclosure and shall be equipped with an insect screen.
7. The engine shall be started by an electrical cranking motor with power provided from storage batteries, which shall be a 24 volts system. Units under 10 liters engine size can be supplied with 12 volts system.
 - a) Provide sufficient amperage for three cycles of three cranking periods of 15 seconds duration.
 - b) The starting system shall be capable of providing three complete cranking cycles without overheating.
 - c) The system shall include a fully automated battery charger to maintain the battery in a fully charged state, with an alarm to supervisory control and data acquisition (SCADA) in the event of malfunction or low battery voltage.
 - d) Storage batteries shall be provided with quick-disconnects.
 8. The generator set shall be provided with a microprocessor-based control system which is designed to provide automatic starting, monitoring and control functions.
 - a) The control system shall also be designed to allow local monitoring and control of the generator set and remote monitoring and control, suitable for the intended operating environment.
 9. An emergency stop red mushroom head button must be provided.
 10. The generator shall be provided with a dedicated circuit breaker for load bank testing. Generators with an output current of 100 A or greater (80 kW and above for 600 VAC) shall be wired to a load bank connection box with cam-lock style plugs to allow for easy connection of a load bank.
 11. Load bank(s) and if needed, automatic load bank controller, shall be considered for safely testing the generator. Load cell shall be automatic type, or staged cells so that during testing, generator is not subject to insufficient loading. Load bank requirements to be reviewed at the pre-design stage of the project through a load study technical memorandum and will be subject to the final decision of the design team. Region preference is to not use proprietary controllers on equipment.
 12. The generator shall be installed on a concrete pad.
 13. The following apply specifically to indoor generator installations.
 - a) To eliminate hazards to personnel, safety guards shall be provided around all hot surfaces, belts, shafts, gears, rotating equipment and other moving parts.
 - b) All generator exhaust components, from the engine to the exhaust stack lagging, shall be provided with removable non-absorbent mineral wool blanket insulation.
 - c) The designer shall provide stairs and a landing to assist filling of an exterior above grade fuel tanks. Indoor fuel tanks are not permitted.

A.4.8 Electrical

A.4.8.1 Design Vision

Electrical systems shall be designed to support the process, control and monitoring infrastructure that relies on them. The design shall focus on reliability and performance needs of equipment, risk reduction, and safety. Electrical equipment shall be provided in protected locations, of sufficient quality and redundancy, so that critical processes are protected from nuisance and catastrophic failures due to electrical malfunction.

1. Seek simplicity where possible.
 - a) Utilize soft starters in place of variable frequency drives (VFDs), where feasible.
 - b) Preference for electrical panels/equipment to be placed in indoor electrical rooms, if the applicable indoor space is not available then an outdoor bus shelter-type kiosk is to be utilized,
 - c) Use outdoor stand-alone generators in place of engineered buildings unless otherwise stated or approved by staff.
 - d) Keep electrical equipment out of hazardous spaces, and;
 - e) Provide backup soft starters for pumps larger than 100Hp; to be reviewed at the design stage of the project and subject to the final decision of the design team.
 - f) Group essential and non-essential loads to facilitate simplistic load shedding schemes for utility power failures
2. Consultant to confirm the adequacy of the available incoming power with respective hydro utility company. Consideration shall be given to test the incoming power using power monitors to check for unusual power spikes.
3. Load shedding schemes shall be deployed to automatically shed non-essential loads during a utility power failure. Load shedding shall not be dependent on any proprietary controllers or equipment not explicitly listed in the W&WW Division's Approved Product and Equipment list (APEL) or Automation (SCADA) Standards.
4. Important electrical equipment shall be kept separate from chlorine storage, to prevent accelerated corrosion.
5. Electrical equipment placed in underground chambers should be avoided and where necessary shall be protected with a sump pump, the chamber shall be waterproofed, and devices shall meet NFPA 820 rules (explosion proof heaters, etc.). SCADA equipment shall not be placed in chambers.
6. An electrical system coordination study must be completed to confirm electrical system protection and setting of protective devices under normal utility and facility standby power.
7. Where VFD equipment is being used, a harmonics study is required.

8. The designer is responsible for the updating and production of all single line diagrams in the facility where they have changed or modified the electrical power supply system.

A.4.8.2 Design Features

Electrical systems shall be designed with the following features:

1. Lamacoid nameplates shall be provided for all electrical equipment.
2. All wiring must be identified with permanent indelible machine printed identifying wire markers on both ends of the phase conductors of feeders and branch circuit wiring.
 - a) The phase sequence and colour coding must be maintained throughout, complying with the Canadian Standards Association C22.1 (CSA C22.1) colour code.
 - b) The control wiring must have an identical tag at both ends, including the junction box. The junction box shall have a terminal box.
3. All electric motors greater than 7.5 KW (10 HP) shall be high efficiency motors. For motors greater than 89.5 KW (120 HP), the minimum efficiency shall not be less than 94% at the specified operating point. However, the final determination shall be made based on life cycle costing analysis.
4. Multilins must be provided for soft start motors greater than 89.5 KW (120 HP).
5. The service entrance shall be protected via transient voltage surge suppression (TVSS) and lightning arresters.
6. Power monitoring on incoming feeders, VFDs, Multilins must be provided and connected to SCADA using Ethernet/IP communications protocol. Note: Controls for VFDs will still be hardwired.
7. For critical facilities, two separate feeds (with tie breaker) shall be installed to allow for the isolation of one feed while maintaining 75% of the total station load.
8. Single line diagrams shall be “arch D” size, water resistant, plaque mounted and must be posted in all buildings.
9. MCCs (NEMA ICS 2-322) must be provided for all 600V and 4160V equipment.
 - a) Indoor MCCs shall be NEMA/EEMAC 1A gasket enclosure and outdoor NEMA/EEMAC 3R enclosures.
 - b) Evaluate the cost benefit of NEMA/EEMAC 4X outdoor enclosures on a project specific basis.
 - c) A main breaker and individual lockage disconnects shall be provided for each starter, complete with removal buckets.
 - d) Arc flash labels shall be provided.
 - e) Lockable equipment disconnects at MCC shall be provided.

- f) Local disconnects shall also be provided unless their location would be prone to flooding and damage.
10. All electrical equipment including MCCs and control panels shall be located on the main floor of a facility or if outdoors on a concrete pad all above the regional flood line.
 11. Concrete pad shall be 150mm high.
 12. A minimum 1m clearance in front of all electrical equipment is to be maintained. All panel doors and access doors must be able to open a minimum of 90 degrees
 13. Insulation resistance tests shall be performed for all wiring and equipment installed.
 14. Electrical junction boxes and panels shall be mounted above flood plain elevations or potential submergence levels.
 15. A free standing automatic transfer switch shall be provided for all facilities with permanent generators.
 16. A free standing manual transfer switch shall be provided for all facilities without permanent generators.
 17. The transfer switch and its controls shall be stand alone, independent and not integrated into the electrical switchgear and protective devices.
 18. All conduits within driveways or roadways must be concrete encased complete with a 50% spare conduit capacity.
 19. The preferred luminaire type for indoor and outdoor applications is light-emitting diode (LED). Photocell control for all outdoor lighting applications must be provided.
 20. Outdoor light fixtures shall comply with the Niagara Region Water and Wastewater Security Technical Specifications, latest revision, for security lighting standards, as well as the Dark Skies Compliant Energy Efficiency Standards.
 21. For indoor lighting fixtures, the following shall be provided.
 - a) Lighting shall be energy efficient.
 - b) The designer shall be responsible for conducting a photometric assessment to confirm the necessary number of units and optimum locations.
 - c) Locating light fixtures on high ceilings shall be avoided. For light fixtures that must be located on very high ceilings, access shall be provided for servicing by crane or other practical alternate means of accessibility.
 - d) For energy savings, occupancy sensors shall be provided for indoor lighting where reasonably practical.
 22. Emergency lighting with battery packs shall be provided for each building that is not serviced by the emergency backup generator.
 23. All electrical equipment shall be designed for 1m clearance for workability and maintenance purposes.

A.4.8.3 Equipment Tagging

1. Flat surfaces shall be provided with lamacoid nameplates.
2. Equipment having curved surfaces shall be supplied with stainless steel engraved tags complete with stainless steel chain affixed to the equipment.
3. Equipment tagging shall follow the device position labelling in the Niagara Region Automation Standards

A.4.9 Instrumentation and Control

A.4.9.1 Design Vision

All instruments shall be installed in a location that is safe for workers, easily accessible, serviceable and efficiently calibrated. Devices shall be suitable for their intended environment. Controls must follow the Niagara Region Automation Standards.

A.4.9.2 Design Features

In general, the following instruments shall be a standard:

1. Flow measurement instruments within pressure pipe systems shall be with electromagnetic flowmeters.
2. Ultrasonic level transmitters with a flume are preferred for flow measurement in consistent or frequent flowing open channels or gravity pipelines such as in treatment plant overflows/outfalls or for municipal billing meter applications
3. Non-contact area velocity flowmeters (preferred) or V-notch weir with level transmitter are preferred for flow measurement in infrequently flowing open channels or gravity pipelines such as in sewage pump station overflows.
4. Level measurement shall be by ultrasonic (preferred), pressure or radar transmitters (digesters only).
 - a) Provide backup float system.
 - b) Preference shall be given to ultrasonic transmitters.
 - c) Level measurement design, and selected technology, shall take into account atmospheric conditions (i.e. steam, mist, etc.), floating debris, foam, loss of echo potential, etc.
 - d) Ensure that the face of the transmitter does not make contact with the liquid during flooding, or high-level conditions, where the transmitter may be submerged (i.e. provide flood cap, etc.).
5. Pressure transmitters shall be utilized instead of pressure switches.
6. Heat detectors shall be implemented in generator building rooms instead of smoke detectors.

A.4.9.3 Equipment Tagging

1. Flat surfaces shall be provided with lamacoid nameplates.
2. Equipment having curved surfaces shall be supplied with stainless steel engraved tags complete with stainless steel chain affixed to the equipment.
3. Equipment tagging shall follow the device position labelling in the Niagara Region Automation Standards

A.4.9.4 Communications Protocol

1. The Niagara Region's standard communication protocol for industrial networks is Ethernet/IP. If a device is not capable of communicating with Ethernet/IP, then a standalone industrial communications gateway must be installed to allow for Ethernet/IP communications.

A.4.9.5 Online Vibration Analysis

1. For pumps and motors 100HP and greater, permanent vibration monitoring shall be installed and integrated into SCADA via a PLC, using the Ethernet/IP communications protocol.

SECTION B - Water

B.1 Water Treatment Plants

B.1.1 Design Vision

Niagara Region's goal is to produce potable water that not only complies with the requirements of the Ontario Drinking Water Quality Standards (ODWQS), but also meets treated water quality objectives that in certain cases may be more stringent than the ODWQS. Internal plant operating objectives (working levels) identified in this section have been developed for various treated water quality parameters for Niagara Region's Water Treatment Plants (WTPs).

The construction of a new water treatment plant will likely be specific to the treatment needs of the source water. Typically, it is considered more practical to supply new service areas from existing treatment plants rather than constructing a new treatment plant.

The goal of a water treatment plant is to provide efficient and reliable removal and/or inactivation of contaminants and/or pathogens from the source water and supply treated water to the storage facilities and ultimately the customers. Treatment plants shall have sufficient backup controls and devices to allow for effective maintenance of all equipment without upset to treatment processes or impacts to the storage and distribution system.

B.1.2 Basis of Design

1. Niagara Region's water treatment plants must be capable of meeting the mandated requirements as stipulated in the *Drinking Water System Regulation (O. Reg. 170/03)* as well as the conditions specified in the Drinking Water Works Permit (DWWP) and Municipal Drinking Water License (MDWL) issued by *MECP* for these facilities.
 - a) All equipment contacting water must be NSF approved (NSF International) as stipulated in the MDWL. This includes but is not limited to NSF-61 and NSF-372.
 - b) Any water residuals that are to be discharged to the sewer or wastewater treatment plant must consider and adhere to Niagara Region's, or local, Sewer Use Bylaw.

B.1.3 Facility Layout

In designing the layout of water treatment plants, consideration shall be given for future expansions of the plant to its ultimate site capacity in order to maximize use of available space on the property.

1. The designer shall in all cases give consideration to maximizing the site ultimate capacity in planning the plant layout, which in the future may be higher than capacity requirements as identified in the Water and Wastewater Master Servicing Plan.
2. Design of the expansion works shall be carried out to permit the orderly construction of the facility economically with minimal disruption of the existing facility.
3. Works must be designed for proper flow splitting at each step in the overall treatment train. Interconnections between equivalent treatment processes from different stages of overall plant development shall be incorporated into the design wherever possible.

4. No equipment, heating pipes, chemical pipes / tubing, or other pipes / tubing / conduits containing material that could cause contamination shall be installed directly over tanks, filters, etc. (i.e. open water).

B.1.4 Treatment Processes and Equipment

B.1.4.1 Water Source

Designer must also take into consideration the latest version of the *Source Protection Plan* for the Niagara Peninsula Source Protection Area prepared under the Clean Water Act and the established intake protection zones (IPZ's) described in that document. Furthermore, designers must take into consideration policies and procedures put in place to minimize potential threats to raw water quality in the design of new water sources and modifications to existing sources or intakes.

Where necessary the designer must provide revisions to the *Source Protection Plan*.

B.1.4.2 Water Intakes

The designer shall take into account the Region of Niagara requirement for pre chlorination at all raw water intake sites for the prevention of Zebra Mussel colonization of these structures and associated piping.

Design of water intakes and associated structures shall take into consideration the potential for formation of frazil ice which can sink and block intakes. The designer shall include features or means to address the formation of frazil ice.

Intakes shall have a minimum of 600mm of clearance from the water bed unless shown that a lesser clearance will not impact the function of the intake.

B.1.4.3 Low Lift Pumping

Low lift pumping stations shall be equipped with vertical turbine pumps and shall be designed without the use of foot valves.

The designer is required to comply with the general intent of Section B, Item 3.0 Water Booster Pumping Stations.

B.1.4.4 Disinfection Processes

In an effort to reduce the formation of disinfection byproducts (DBP's) such as Trihalomethanes (THM) and Haloacetic acids (HAA), the Niagara Region has adopted the following disinfection process which the designer is required to comply with in all future upgrades and expansion of water treatment facilities.

1. Disinfection will be provided using ultraviolet and/or a liquid chlorine solution (sodium hypochlorite) and operating with a free chlorine residual.
2. Disinfection shall meet the plant's Environmental Compliance Approval (ECA) treatment capacity and the required level of redundancy.
3. Adequate chlorine contact time (CT) must be achieved on the plant property rather than relying on a transmission main for CT. i.e: CT time must be obtained prior to the

water leaving the last storage tank at the Treatment Plant and prior to service water take off for potable plant use.

4. Processes such as chemically-assisted filtration shall be provided that will be designed to enhance organics removal in order to reduce DBP formation potential.
5. It is recommended that a multi-barrier approach be used for cyst or oocyst removal/inactivation as a matter of good design practice and as a highly favourable approach with regulatory agencies including MECP and the United States Environmental Protection Agency (USEPA).
 - a) As a primary barrier of treatment, conventional treatment technologies (coagulation, flocculation, sedimentation, and filtration) shall be optimized to ensure high solids removal efficiency.
 - b) Generally, chlorination following conventional treatment is an effective disinfection strategy for giardia inactivation removal, meeting the MECP CT requirement.
 - c) Niagara Region’s Water Treatment Plants shall be designed to achieve at least 99% (2-log) removal of cryptosporidium oocysts, 99.9% (3-log) removal of giardia cysts, and 99.99% (4-log removal) of viruses through conventional filtration (or alternative technology) and primary disinfection.

B.1.4.5 Taste and Odour Reduction

Performance requirements for taste and odour reduction systems will depend on the Methyl Isoborneol (MIB) and Geosmin concentrations, expressed in ng/L (nanograms per litre) present in the influent to the water plant. The following table indicates recommended performance requirements for MIB and Geosmin removal.

Influent Water MIB or Geosmin Concentrations (ng/L)	Treated Water MIB Maximum Concentration (ng/L) or Minimum Percentage Removal	Treated Water Geosmin Maximum Concentration (ng/L) or Minimum Percentage Removal
< 100 ng/L	< 10 ng/L	< 10 ng/L
100 ng/L or greater	90%	90%

For plants using granular activated carbon (GAC), the system design shall take into consideration selection of the appropriate type of media, loading rates, empty bed contact times (EBCT), mass transfer zones (MTZ), and absorption factors in order to meet Region design objectives. Pilot testing of new systems or new media shall be conducted to confirm the basis for detailed system design. Refer to the *Niagara Region Filter Media Replacement Specification*.

B.1.4.6 Coagulation and Flocculation

The designer shall evaluate and recommend the most appropriate coagulant chemicals and system configuration in consultation with Niagara Region.

1. The designer shall provide a minimum of two trains, sized such that with one train out of service the remaining train(s) are sized to handle a minimum of one half of the ECA capacity. Each train shall be capable of operating independently.
2. Flocculation of raw water prior to sedimentation should be adequate for the source and characteristics of the raw water. Flocculation shall be either by mechanical or hydraulic mixing.

B.1.4.7 Sedimentation

Sedimentation tanks shall be designed for the efficient removal of particulate matter using plate settlers. A minimum of two trains shall be provided, sized such that with one train out of service the remaining train(s) are sized to handle a minimum of one half of the ECA capacity. Each train shall be capable of operating independently. Alternative technologies for the removal of particulate matter may be used if agreed to by, or identified by, Niagara Region.

For efficient operation of sedimentation processes, ensure that:

1. Sedimentation tanks shall be provided with potable water hose stations for cleaning and removal of sludge. Alternative cleaning technologies shall also be considered.
2. Automated sludge removal is the preferred solution where feasible.
3. The bottom of sedimentation tanks shall be sloped to a sump for periodic sludge removal. It is preferable that the sump shall be provided with a drainage pipe for discharge of wastewater by gravity where a suitable gravity outlet is available.
4. Where gravity outlet is not feasible, sumps shall be sized and oriented for operation with a portable submersible pump. All electrical connections required for such an operation shall be included. An appropriate location for the outlet must be selected for the removal of sludge by discharge to local sanitary sewer where available.
5. A means of isolating individual sedimentation tanks must be provided.
6. Process residuals shall be directed to the sedimentation tanks to settle out as much solids as possible.

B.1.4.8 Filtration

General

The *MECP Procedure for Disinfection of Drinking Water in Ontario* includes acceptable minimum standards for the design and operation of a conventional surface water treatment plant using coagulation, mixing, flocculation and sedimentation followed by filtration. In order to produce potable water with the lowest turbidity level, the following is required in all Region water treatment plant filtration systems.

1. Turbidity on each filter effluent line must be monitored to predict filter breakthrough and begin backwashing prior to breakthrough.
2. Air scour and backwash water systems shall be provided.
3. Plant performance shall be monitored for compliance with regulations to receive disinfection credits.
4. The unit process performance within the WTP shall be monitored.
5. Any filtered water that does not meet operational objectives for filter effluent must be rejected to waste.
6. Microbial removal must be maximized.
7. Halogenated DBP formation when chlorine is added must be minimized.
8. Chlorine addition must be minimized by removing material that increases chlorine demand.

Filter Design Objectives

Niagara Region has adopted the operating objective of 0.10 nephelometric turbidity units (NTUs) or lower for filter effluent turbidity. For turbidity control set points see the current version of *Niagara Region's Standard Operating Procedure (SOP) CCP: Filter Effluent Turbidity*.

Filter Operation

1. The designer shall provide design details of the filter operation in the pre-design report which shall, at a minimum, include the following components.
 - a) Filter Operation Description
 - b) Filter Layout and Cross-section Drawing(s)
 - c) Filter Instrumentation and Control
 - d) Filter Media
 - e) Backwash Pump and Motor Data
 - f) Backwash Wastewater Holding Tank
 - g) Air Scour System
 - h) Underdrain
2. At a minimum, the filters shall be provided with instrumentation for the monitoring of the following to ensure proper operation.
 - a) Loss of head indicator
 - b) Filtration Runtime
 - c) Flow from each filter effluent line

- d) Flow from each filter-to-waste line
 - e) Backwash flow rate to each filter
 - f) Effluent turbidity monitoring on each filter effluent line
3. Filters shall be provided with the characteristics for normal automatic operation as stipulated in *Niagara Region's SOP for Turbidity*. A detailed process description of filter operation and conditions that would trigger initiation of a backwash sequence shall be defined in the Process Control Narrative and the Operations Manual for the plant.
 4. The backwash method for filter media shall include the air scour method as part of backwash. No other filter backwash method will be accepted.
 5. Granular filter media shall comply with AWWA B100 Granular Filter Material and the *Niagara Region Filter Media Replacement Specification*.

B.1.4.9 High Lift Pumping

High lift pumping must comply with the general intent of Section B, Item 3.0 Water Booster Pumping Stations.

All high lift pumps must be design for and sized according to the needs of the fully automated operation of the treatment facility on SCADA.

All high lift pumping stations must have provisions for overpressure relief routed back to the pump well. The need for provisions for surge anticipating pressure relief should be investigated during pre-design of all pump stations.

For distribution systems where there is only one storage tank regulating pressure on the distribution system, high lift pumping stations shall be designed with alternative supply piping, valves, PRVs and associated controls to be able to feed the Region transmission system, and ultimately the LAM distribution system, at a constant defined pressure when that external storage tanks is taken offline for maintenance. The alternate controls scheme shall use flow and pressure leaving the high lift pumping station to control the start and stop of the pumps.

B.1.4.10 Chemical Feed Systems

The designer shall refer to the latest edition of the *Niagara Region Water Chemical System Design Standard*.

1. For monitoring flow of sodium hypochlorite and de-chlorination chemicals, Niagara Region prefers the use of flowmeters. The design shall accommodate Niagara Region's critical control points for no-flow conditions and for compliance with *Niagara Region's Quality Management System*. For coagulant chemicals, Niagara Region prefers the use of magnetic flowmeters.
2. In chemical filling areas, a spill containment area shall be designed to include the vehicle loading area and hose connections.

3. Monitoring equipment shall be designed to allow for the measurement of residual chlorine to 0.02 milligrams per liter (mg/l) to allow for appropriate disinfection dosage.
4. Chemical feed systems shall be on their own dedicated electrical circuit.
5. NEMA 4 Rated Enclosures shall be provided.

B.1.4.11 Residuals Management

Niagara Region requires that settled sludge from the treatment of residuals be discharged to a local sanitary sewer where available or the supernatant de-chlorinated prior to being discharged to the environment.

B.1.4.12 SCADA

The following water treatment processes shall be fully automated: (essentially the entire plant should be able to operate on its own with only monitoring of the process performed by the operating staff)

1. Inlet Works
2. Low Lift Pumping system to meet plant throughput demand
3. Flocculation System
4. Sedimentation System
5. Filtration including:
 - a) Flow equalization of flocculated raw water to each required filter
 - b) Rate of Filtration
 - c) Filter Backwashing
 - d) Air Scour Backwash System
6. High Lift Pumping system to meet water distribution system demand
7. Chemical System for:
 - a) Coagulation
 - b) Taste and Odour Control (if applicable)
 - c) Disinfection
 - d) Zebra mussel control
 - e) pH Adjustment
 - f) Chlorination of backwash water
8. UV Disinfection System
9. Residual Waste Management System
10. Distribution Monitoring

B.2 Water Transmission Systems

B.2.1 Design Vision

Niagara Region's vision is to design a reliable, energy efficient, structurally sound water transmission system that can sustain all operating and surge pressures, accommodate future growth, minimize the water age, and can be easily serviced by maintenance staff while minimizing the need for confined space entries.

B.2.2 Basis of Design

This section outlines the minimum requirements for the design of water supply transmission systems.

B.2.2.1 Design Water Demand

The Region's transmission system shall be designed to meet the following criteria.

1. Peak hourly demand plus fire flow.
2. Pressure in a transmission main is not to be less than 275 kilopascals (kPa) / 50 pounds per square inch (psi) during peak hour demands at hydrant elevation (1.0m above ground level).
3. Pressure in a transmission main under the condition of simultaneous peak hour flow and fire flow demands is to be not less than 210 kPa (30 psi) at the point in the Region system when the fire flow is being drawn. The designer also must ensure that there is the same or increase in residual pressure in the local system, during fire flows, with the new transmission main.

B.2.2.2 Fire Flow

Fire flow requirements shall meet the criteria used in the current version of the Niagara Region's Water and Wastewater Master Servicing Plan.

B.2.2.3 Equivalent Population

Please refer to the current *Niagara Region's Water and Wastewater Master Servicing Plan* for estimation of water service demand for the different types of developments in the design of water transmission systems.

B.2.2.4 Design Factors

For average daily demand values, maximum day factors and maximum hourly demand peaking factors, use actual flow data for derivation of base values. If no current data exists, refer to the current version of *Niagara Region's Water and Wastewater Master Servicing Plan* and use best practices.

B.2.2.5 Pressure

Transmission mains shall be designed to withstand all surge and transient pressures and full vacuum without consideration for benefit provided by air/ vacuum valves. That is, transmission mains shall be designed as if air/ vacuum valves are not operational.

Transient analyses shall be part of the engineering scope for all transmission mains and booster pumping stations.

B.2.3 System Layout

B.2.3.1 Transmission System

The transmission system shall be designed to ensure flexibility of operation and to minimize the area of the community affected by shutdowns during water transmission network repairs. The designer shall demonstrate that water quality can be maintained throughout the transmission system. The designer shall consider the following in the design of the water transmission system:

1. The use of easements to loop transmission mains shall be minimized. Looping mains shall not be used to rectify problems with water age/chlorine residuals.
2. Mains shall be routed, and where possible sized, to minimize the age of water through the transmission and distribution systems.
3. It is preferable to transmit treated water from the high lift pumping station directly to storage facility without connections to distribution system.
4. Velocity in transmission main should be above 0.6m/s and are preferred not to exceed 1.5 m/s. For higher velocities, life cycle costs must be evaluated.
5. Other than the Water Treatment Plant service water, private service connections are prohibited on transmission mains.

B.2.3.2 Separation from Sewer and Wastewater Mains

The designer shall design transmission mains to ensure adequate horizontal and vertical separation between sewers and watermains.

1. Where transmission mains crossing above or below sanitary and storm sewers have insufficient cover and/or separation, the transmission main shall be completely encased with a minimum of 50mm of polystyrene insulation wrap. Insulation thickness shall be designed to provide a minimum time to ice development after flow stoppage of 48 hours assuming the sewer is at minimum outdoor ambient temperature.
2. Where the specified vertical separation cannot be achieved, the storm and/or sanitary sewer shall be constructed of material and with joints that will comply with watermain construction standards and shall be pressure tested to ensure water tightness.

B.2.4 Pipe Requirements

B.2.4.1 Pipe Sizes, Material and Valves

1. All pipes shall have a minimum designed pressure rating of 1620 kPa (235 psi) unless lower system and surge pressures can be substantiated through the transient analysis to permit the reduction of the designed pressure rating to a minimum of 1135 kPa (165psi).
2. All pipes to be manufactured with a cast iron outside diameter (CIOD).

3. Transmission mains shall be sized for future growth as per the most current version of *Niagara Region's Water and Wastewater Master Servicing Plan*. Designers shall size transmission mains so as to maintain water quality but avoid unacceptable future changes in the pressure zone hydraulic grade line. All pipes shall have a maximum designed velocity of 1.5 m/s at peak hour demand.
4. The size, functionality and operational philosophy of the transmission main shall be reviewed with operations and engineering staff and determined at the preliminary design stage.
5. The designer shall include as part of the pre-design report the reasons for the selection of the proposed pipe material for the project. Where an alternative material is acceptable, the designer shall indicate this in the report and include a cost/benefit analysis of the acceptable alternative.
6. The following pipe materials are acceptable for transmission mains
 - a) Standard poly-vinyl chloride (PVC)
 - b) Fusible PVC
 - c) Molecularly oriented PVC (PVCO)
 - d) Concrete pressure pipe (CPP)
 - e) HDPE (Trenchless Crossings only)
 - f) Stainless Steel (316L-North American) inside facilities and chambers
7. Interior piping and penetrations through chamber or concrete walls shall be stainless steel. Transition from stainless to all other pipe materials shall be completed outside the concrete or chamber wall.
8. In determining the suitable pipe class to be used, thrust force, internal pressure, surge pressure, live load, dead load, soil type and trench conditions shall be considered in the calculation. The above calculations and pipe manufacturer's recommendations shall be incorporated into the design and included in all design submissions.
9. Maximum allowable pipe joint deflection shall be 70% of the manufacturer's specifications. Pipe barrel bending/deflection will not be permitted except for HDPE pipe. Maximum pipe bending for HDPE pipe is preferred to be 80% of the maximum allowable radius stated by the manufacturer.

Pipe and Fitting Materials

Material	Joint Type	Specification	Fittings
Polyvinyl Chloride	Gasketed Bell & Spigot	AWWA C900 & C905, CSA B137.3	PVC: AWWA C900, C905, C907, CSA B137.2, B137.3
Fusible Polyvinyl Chloride	Fused joints	AWWA C900 & C905, CSA B137.3	PVC: AWWA C900, C905, C907, CSA B137.2, B137.3
Molecularly-oriented PVCO	Gasketed Bell & Spigot	AWWA C909	PVC: AWWA C900, C905, C907, CSA B137.2, B137.3
Stainless Steel	Welded	ASTM A312, Grade 316L, minimum Schedule 10S	Stainless Steel, Type 316L, ASTM A403
High Density Polyethylene (HDPE)	Butt fused and, only when shown as necessary, fused coupling	AWWA C906	HDPE - AWWA C906 Electrofusion
Pre-tensioned Conc. Cylinder Pipe	Gasketed Bell & Spigot with wrap-around cement mortar diaphragms	AWWA C303	Concrete – AWWA C303
Pre-stressed Concrete, Lined Cylinder Pipe	Gasketed Bell & Spigot with wrap-around cement mortar diaphragms	AWWA C301 & C304	Concrete – AWWA C301 & C304
Pre-stressed Concrete, Embedded Cylinder Pipe	Gasketed Bell & Spigot with wrap-around cement mortar diaphragms	AWWA C301 & C304	Concrete – AWWA C301 & C304

B.2.4.2 Thrust Restraint

1. All transmission mains and thrust restraints shall be designed to withstand the maximum operating pressure plus the surge pressure to which it will be subjected. The design pressure shall not be less than that specified in Ontario Provincial Standard Specification 441 (OPSS.MUNI 441) as amended.

2. All plugs, caps, tees and bends will have approved mechanical thrust restraints. Concrete thrust blocks shall not be allowed other than in chambers.

B.2.4.3 Pipe Depth

1. Transmission watermains shall have a minimum 2.0m cover. Where a reduction of cover is required for technical reasons then the water transmission main shall be completely encased with a minimum of 50mm of polystyrene insulation wrap with applicable jacketing where 1.8m cover cannot be maintained. Insulation thickness shall be designed to provide a minimum time to ice development, after flow stoppage, of 48 hours.
2. In areas where minimum cover cannot be achieved, special provision shall be considered to protect pipe from live loading.
3. Transmission mains shall be deep enough to provide sufficient head room in valve chambers.
4. Under open ditch or unimproved roads, a minimum cover of 2.4m shall be provided to allow for future road improvements or lowering of the road profile.

B.2.4.4 Bedding and Backfill

1. Refer to General Section – Civil.

B.2.4.5 Valves

1. Under normal circumstances on transmission mains, three valves shall be provided on a tee intersection and four valves shall be provided on a cross intersection.
2. Line isolation valves shall be spaced a maximum of 500m apart and shall be the same size as the transmission main.
3. All chambers shall be equipped with a flushing port or drain valve.
4. Drain valves shall be provided at each significant low point for transmission mains. All drain valves are to be located in a chamber. The valves shall have a stainless steel extension stem through the chamber roof in order to operate from the surface. Blind flanges are to be fitted at all drain locations.
5. Air release valves shall be provided at all significant high points on transmission mains. Where air release valves are located in chambers, they shall be provided with an isolation valve and vent lines that include a double check valve assembly for flood protection. All air release valves are to be installed on a tee connection that is to have a diameter of at least 1/3 of the main line diameter and no less than 150mm diameter. As reviewed on a case by case basis, on PVC pipe 300mm diameter or less, the Region may permit the installation of an air valve on a stainless steel service saddle without the need to transition to stainless steel inside the chamber. Air lines shall include a quick connect union for easy removal of air valve.
6. The inclusion of pressure reducing or pressure sustaining valves into transmission main will be considered on a project-specific basis.

7. In areas where local watermains are not present, consideration shall be given to install hydrants on the transmission main for flushing purposes. The requirement for hydrants to be reviewed at the pre-design stage of the project and subject to the final decision of the design team.

B.2.4.6 Corrosion Prevention

The designer shall ensure that all metallic components in the water transmission system are protected from corrosion with appropriate protection measures.

1. As a minimum, buried metallic components shall be protected from corrosion using three-part petrolatum tape meeting International Organization for Standardization 9001 (ISO 9001 standards).
2. All components of the corrosion protection shall be supplied by the same manufacturer/ supplier.
3. All exposed metallic components shall be stainless steel or be protected from corrosion with a factory applied high performance fusion bonded or 2 part liquid epoxy coating. Specifications must fully identify protection requirements for transportation and handling on site; inspection requirements and procedures for required repairs to surfaces damaged prior to and/or during installation. Valve actuators to be protected from corrosion using three-part petrolatum tape meeting International Organization for Standardization 9001 (ISO 9001 standards)

B.2.4.7 Tracer Wire

Refer to General Section – Civil.

B.3 Water Booster Pumping Stations

B.3.1 Design Vision

The overall objective is to design booster pumping stations that are reliable, safe, adaptable, energy efficient, simple to operate, easy to maintain, meet all applicable standards, and provide a high level of service to Region customers.

B.3.2 Basis of Design

Designers shall take into consideration the following, at a minimum, when designing water pumping stations:

1. The requirements of the Hydraulic Institute with respect to overall hydraulic design shall be followed. The designer shall pay particular attention to suction conditions for all pumps to avoid cavitation under all anticipated operating conditions.
2. Underground flowmeter chambers shall be equipped with power supply, means of access and egress that are compliant with the Occupational Health and Safety Administration (OHSA) requirements, flood detection, and communications.
 - a) Control cabinets shall be installed in a common enclosure/building with other equipment. If the station is below ground, control cabinets shall be located above ground adjacent to the flowmeter chamber in an all-weather enclosure.

- b) Control cabinets shall be weatherproof stainless steel enclosures to avoid the need for confined space entry.
- c) Chamber structures shall be provided with approved waterproofing.
- 3. Pipe sizing to and from station must be evaluated to accommodate future expansion where practical.
- 4. The pumps selected shall cover the entire expected range of flows, including minimum flows and maximum day plus fire flows.
- 5. Flow circulation and water temperature rise shall be considered and evaluated for all stations during all combinations of possible demand scenarios including operation during fire flows.
- 6. The advantages and disadvantages of available pump station configurations shall be evaluated, including storage with re-pumping. Single in-line booster pumping is not to be considered.
- 7. The designer shall allow for the ability to isolate individual pumps.
- 8. Station bypass complete with check valve shall be provided.
- 9. For larger stations, costs and benefits of more than one discharge watermain shall be assessed.
- 10. A means of flood protection, detection, and alarming shall be provided.
- 11. The designer shall provide pressure and surge relief valves and piping. Note that Region prefers not to use hydropneumatic surge tanks.
- 12. A flowmeter shall be provided, at least, on each watermain leaving the station. A pressure transmitter shall be provided on each watermain entering and leaving the station.

B.3.3 Facility Layout

Facilities shall consider the following:

- 1. The layout shall provide access for emergency vehicles and cranes.
- 2. The potential for flooding especially in flood plains must be considered.
- 3. Sufficient parking for maintenance and operational vehicles must be provided.
- 4. The design must consider noise controls.
- 5. On site backup generator.

B.3.4 Process Equipment

B.3.4.1 Pumps

The following shall apply to pumping systems:

1. The designer shall refer to the Hydraulics Institute for the design of pumping and piping systems. Particular attention shall be given to pump suction conditions and suction piping. Velocity in pump suction header must be 1.0 m/s or less in all cases.
2. Pumping systems shall be designed to have adequate available net positive suction head (NPSHA) that is greater than required net positive suction head (NPSHR) and include a 1.5 m safety margin applied to NPSHA.
3. Pumps shall typically be equipped with soft starters and shall be designed without the use of foot valves. VFDs will be considered only on a case-by-case basis and shall be agreed to by Niagara Region.
4. The designer shall size pumps and appurtenances according to the flows expected during the lifecycle of the facility and shall consider provisions for staging of pump sizes where applicable.

B.3.4.2 Pressure and Surge Protection

Pressure relief and surge protection on a pump's discharge header shall be provided, and water shall be recirculated back to the reservoir where a reservoir exists, to the supply header or to the environment as applicable. Surge protection shall be designed on a site-specific basis and may include drainage to a local storm sewer or discharge to the environment with an air gap and de-chlorination.

B.3.5 Process Control

All instrumentation, appurtenances and a control system shall be provided as necessary to meet Niagara Region's requirement that the water booster pumping station be fully capable of unmanned automatic operation and fully monitored/controlled from the Water Treatment Plant.

B.4 Potable Water Storage

B.4.1 All Potable Water Storage Facilities (Reservoirs and Elevated Tanks)

B.4.1.1 Design Vision

1. Niagara Region's goal is to provide potable water storage that is watertight, energy efficiency, integrates well with the overall water supply and distribution systems, maintains a high level of water quality, maintains uniform water quality, and provides a high level of service to Region customers.
2. Overall system storage as well as individual storage reservoirs/elevated tanks shall be sized to have storage components for operational needs, demand balancing (Max-Day demand), LAM fireflow requirements, and emergency storage. Reservoir capacity at the Water Treatment Plants prior to CT time are not to be used in the calculation of these storage components.
3. New, retrofits and rehabilitation of reservoirs/elevated tanks shall consider the triple bottom line (Economic, Social, and Environmental) comparison of status quo versus options for change to operational flow philosophy and to ensure water quality, minimize disinfection losses and minimize water age. True life cycle costs are to be

assessed including any differences in pumping requirements at water treatment plants, other storage reservoirs and booster pump stations. This evaluation shall consider option(s) for changing the reservoir supply to a dedicated supply main without connections to distribution system.

4. Where a chlorination booster system is required it shall be designed per the requirements of Section B5 – Chlorine Booster System
5. The designer shall ensure that all water reservoirs/elevated tanks have sufficient overflow capacity, sufficient ventilation capacity, and are watertight with reasonable access for maintenance.

B.4.1.2 Process and Equipment

1. To allow for proper operation during reservoir maintenance/cleaning of single reservoir systems, valving, appurtenances and controls should be provided at the WTP high lift pumping station to allow for safely pressurizing of the system (with pressure relief and related controls) when the reservoir is taken offline.
2. Alternatively, for systems where multiple storage facilities are in use or proposed, the designer must show how individual storage facilities can be taken offline for maintenance/cleaning while not affecting the ability to store and supply water throughout the expected demand scenarios. Region's preference is to not have to provide pressure relief in the distribution system when taking any storage component out of service. All pressure relief shall be provided for at the high lift pumping station(s).

B.4.1.3 Reservoir Distribution Centre

A Reservoir Distribution Centre (RDC) is recommended to house electrical panels, chlorine analyzers, valves and other control devices. This should be located in the reservoir control building or in the base of elevated storage towers.

1. RDC shall contain all storage and piping process control devices including valves, check valves, motorized inlet control valves, valve operators, process drains and other ancillary process control and/or instrumentation.
2. For reservoirs, RDC shall include stairs or hatches with ladder access to the reservoir and adequate ventilation. Additional yard piping chambers shall be eliminated and/or reduced to a minimum.

B.4.1.4 Storage Drainage

1. The full capacity of the potable water reservoir or elevated tank shall be designed to be drained by gravity with controlled discharge to the municipal storm drainage system.
2. The drainage system shall incorporate a means of dechlorination prior to discharge to the storm drainage system.

B.4.1.5 Process Control

Process control for potable water storage facilities shall be designed to meet the following requirements:

1. The designer shall ensure that the full depth of the potable water storage is available for use.
2. Fire and Emergency Storage components shall be clearly identified on SCADA and controls in place to ensure normal operation utilizes Operation and Max-Day storage components only.
3. The flow of potable water out of a storage facility shall be metered and chlorine residual monitored.
4. An engineered potable water sampling station shall be provided. A sampling station shall be complete with 10 mm stainless steel piping complete with appropriate stainless steel valves and sink in order to permit samples to be taken at the desired location quickly. The location of sampling points is to be identified at the pre-design phase of the project.

B.4.1.6 Ventilation

1. Vents shall be designed to prevent pressurization/vacuum. At no time shall a storage facility have air space pressurized or under partial vacuum.
2. Vent shall be located at least 900 mm above finished grade and be fitted with stainless steel screens to prevent entry of vermin, birds, and insects.

B.4.1.7 Emergency Overflow

An overflow from a potable water storage is generally not permitted at any time unless emergency conditions arise. The following requirements shall be implemented concerning emergency overflows:

1. A separate instrumentation and control system shall be provided exclusively for this function to alarm and warn of an overflow.
2. Reservoir/Elevated tanks shall be equipped with an overflow system sized to convey 150% of the design year firm capacity of the upstream pumping capacity in the *Niagara Region Water and Wastewater Master Servicing Plan*. Overflow system includes all overflow piping, appurtenances, chamber(s) and receiving infrastructure, from the reservoir to the receiving body (canal/river/lake). Consideration for future flow capacity shall be given. While the use of an overflow weir is not preferable, head on overflow weirs shall not exceed 200 mm.
3. The overflow is to be directed to an overflow chamber. Where connection from the chamber to a sewer is not possible, flows from the chamber will be directed to an overland drainage ditch, and in any case, the ultimate discharge point and/or receiving body will be identified for compliance purposes.
4. The overflow chamber will be complete with a suitable air gap and duckbill type check valve on the discharge.
5. The overflow chamber shall incorporate a de-chlorination system on the downstream discharge comprising of an aluminum basket c/w stainless steel chain connected to a manually operated winch system.

6. Site grading shall take into consideration all effects of potential overflow from the potable water storage drainage system. Management of overflow energy must be taken into account during the design of the facility.
7. Overflows shall not operate as vents.
8. For a multiple cell reservoir, the overflow system shall be capable of handling the full overflow capacity noted above, with one cell offline, regardless of which cell is offline.

B.4.1.8 Instrumentation and Control

The designer shall include the following instruments and control systems in the design:

1. Ultrasonic level transmitter in each reservoir cell/elevated tank.
2. Groundwater level high alarm.
3. Access house and RDC fire alarm.
4. Access house and RDC smoke alarm.
5. Access house and RDC intrusion alarm.
6. RDC flood alarm.
7. RDC low temperature alarm.

B.4.2 Reservoir Storage Requirements

B.4.2.1 Design Vision

1. Reservoirs should only be used instead of an elevated storage tank in cases where their use can be completely substantiated, in economic, environmental and social terms. The Region prefers to pump and add chlorine to potable water only once.
2. Reservoirs shall contain a minimum of two operationally independent cells. Each cell shall be capable of full and independent operation of the pumping station/reservoir system while the other cell(s) is in isolation.

B.4.2.2 Circulation of Fresh Water

1. All inlet, outlet and piping within the potable water reservoir cells shall be designed to allow for a flow through path with minimizing dead zones.
2. Reservoirs, including those at the Water Treatment Plant shall be provided with baffling to achieve at least a T_{10}/T of 0.7. It is mandatory that the baffling be designed in accordance with the Computational Fluid Dynamic (CFD) modeling technique.

B.4.2.3 Process and Equipment

1. All necessary piping and valving must be provided to allow for the bypassing of any reservoir's cell to be taken off-line for maintenance work.
2. A minimum of a two-cell reservoir must be used, with the ability to isolate any one of the reservoir's cells.

3. For water treatment reservoirs, isolation of one cell shall not impact the minimum required CT value.
4. Manually operated butterfly valves shall be provided, as required, as well as piping to permit the isolation of the potable water reservoir cell(s) for maintenance or construction work without having to shut down the entire reservoir.
5. Sufficient valves must be included to allow reservoir cell isolation to facilitate disinfection without impacting operation of other components of the system that must remain in service.
6. Isolation valves shall not be submerged within the reservoir.
7. Washdown supply piping available to the potable water reservoirs shall be sized for two hoses operating at any one time.
8. A stainless steel wash down header must be provided.
9. Connection points must be provided at 30m intervals to cover the entire reservoir floor area.
10. The reservoir washdown system shall be protected by a dedicated backflow preventer.
11. All washdown supply piping and appurtenances shall be fully drainable when not in use.

B.4.2.4 Structural and Layout

The designer shall include the following structural and layout requirements in the design:

1. The design of a buried reservoir roof shall be based on cast-in-place reinforced concrete complete with a membrane overlay. The membrane overlay shall have a 25 year roof warranty. The reservoir roof shall be covered with insulation and soil to a minimum depth of 400 mm.
2. In-ground reservoirs shall be designed with the roof slab sloped to promote drainage, and include a granular zone above the roof, below the cover material.
3. The reservoir base slab floor shall be sloped to sump pit(s).
4. The designer shall ensure that a maximum 50m egress distance is maintained from any location in each cell.

B.4.2.5 Reservoir Hardware

The designer shall include the following requirements in the design:

1. The overflow pipe shall be secured with a SS 316L mesh screen installed within the pipe at a location least susceptible to damage by vandalism.
2. Hardware inside the reservoir, including ladders, handrails, etc., shall be stainless steel Type 316L
3. Two aluminum access hatches, at minimum, shall be provided into each cell.

4. Where possible, access hatches shall be located adjacent to driveways or access roads for convenient access by service vehicles and cranes.
5. Submarine reservoir access hatches shall not be used.
6. Hatches shall be equipped with perimeter drains and limit switches.

B.4.3 Elevated Tank Requirements

B.4.3.1 Design Vision

1. The designer shall complete the site layout for the facility as well as the design of the tank in terms of piping, connections, capacity, hydraulic levels, operating range, instrumentation, and general tank configuration. The detailed design of the tank including structural design and mixing/circulation systems (including Computational Fluid Dynamic Modelling) is to be undertaken as a design-build contract by a specialty contractor with experience in elevated water storage tanks.
2. All elevated storage tanks shall have separate inlet and outlet piping with check valves.

B.4.3.2 Circulation of Fresh Water

1. Elevated tanks shall be provided with a hydrodynamic mixing system (HMS) shall be included to provide uniform water age. Separate inlet and outlet piping must be provided.
2. Rubber “duck-bill” type check valves for mixing. When shown by the designer to be both required and effective, recirculation pumping shall be provided to prevent ice formation and, if needed, equalize water age.

B.4.3.3 Process and Equipment

In addition to the requirements elsewhere in this document, elevated water storage tanks shall be designed to meet the following requirements:

1. Designed to supply peak demand rates at constant system pressures
2. Designed to include capacity for operational volume, flow equalization volume, fire storage volume and emergency volume.
3. All tanks to be designed as per latest AWWA standard
4. Provide a recirculation pump system that has the capability to be manually started at the pump.
5. Provide sample points on the intake and discharge pipes. The sample points will be directed to the outer wall using stainless steel tubing, and will be complete with a shutoff valve. The sample point discharges will be routed to the chlorine analyzer(s).
6. Provide a drainage system to allow for tank cleaning without contaminating riser pipe(s), and connect system into overflow pipe.
7. Provide an appropriate dehumidification system in the valve room.

8. Provide vacuum relief and overflow in tank.
9. Provide separate inlet and outlet piping, both from distribution/transmission mains and throughout facility.
10. Tank inlet mixing system shall be provided to ensure consistent chlorine residuals and ensure elimination of dead zones within tank.
11. Tank inlet elevation shall be determined at the time of mixing system design.

B.4.3.4 Structural and Layout

1. Tank design shall include a minimum 2mm corrosion allowance.
2. Provide a painters rail and drip edge for the elevated tank.
3. Install a watertight access hatch of minimum 600mm diameter at bottom of tank, inside the support pedestal.
4. Provide a safety railing surrounding the top of the tank.
5. Facility will have circular reinforced concrete pedestal to support reservoir tank including all piping, valves, instruments, controls and electrical (other than generator) inside the base.
6. Provide a stairway to the mezzanine level.
7. Provide double door entrance at pedestal base.
8. Seal all floors with a slip resistant coating.
9. Provide a minimum 900mm diameter access tube from the top of the pedestal to the reservoir roof.
10. Install aluminum ladders and platforms inside the pedestal and access tube.
11. The design of elevated tanks shall incorporate a central antenna base support structure for the mounting of communications systems on the top of the elevated storage tank.
12. Elevated tank painting and logos shall be consistent with the Niagara Region Policy for Lettering on Steel Water Storage Tanks & Stand Pipes. Submit three variations of art work to Niagara for review and approval.

B.5 Chlorination Booster Systems

B.5.1 Design Vision

The overall objective is to design chlorination systems that are reliable, safe and simple to operate and meet all applicable design and safety standards. Niagara Region currently uses only UV and liquid chlorine (sodium hypochlorite) for disinfection.

B.5.2 Basis of Design

This section relates primarily to Chlorination Booster Systems and post-chlorination for the purposes of secondary disinfection. Chlorination for the purpose of primary disinfection is addressed under Section B.1 Water Treatment Plants.

The designer shall refer to the latest edition of the *Niagara Region Water Chemical System Design Standard*.

B.5.3 Facility Layout

1. Chemical feed systems shall be in separate areas or rooms, separately ventilated as necessary, to prevent impacts from passive off-gassing from chemicals on sensitive equipment.
2. Spill containment for the chemical filling area must be included in the design. Spill containment area shall also be included for the vehicle loading area and hose connections.
3. The sodium hypochlorite tank(s) and metering pump panel shall be located in a containment area. Requirements for the containment area are as follows:
 - a) The minimum volume of the containment area shall be equal to 110% of the total volume of the sodium hypochlorite storage.
 - b) The containment area shall be rectangular and designed to safely contain sodium hypochlorite at a 12% to 14% strength solution. The containment area will be provided with a chemical resistant coating appropriate for sodium hypochlorite.
 - c) A float level and alarm sensor shall be provided to detect liquid in the containment area. The float level shall be installed in the lowest part of the area. A digital signal complete with suitable transducer and transmit sensor cables shall be supplied with the signal sent to the PLC.

B.5.4 Process Equipment

B.5.4.1 Chemical Metering System Design Features

1. The chemical metering system shall be designed in accordance with the Region's Chemical Design Standards.

SECTION C - **Wastewater**

C.1 Wastewater Linear Systems

C.1.1 Design Vision

The goal of Niagara Region’s wastewater linear system is a reliable wastewater collection system that can accommodate future growth, operate efficiently/economically and minimize maintenance requirements.

Forcemains shall be designed to avoid fouling and plugging and to minimize turbulence and generation of hydrogen sulphide.

C.1.2 Basis of Design

This section outlines the minimum requirements for the design of wastewater collection systems.

C.1.2.1 Flow Calculations

Terms related to dry and wet weather flows are defined as the following.

1. Design RDII (Rain Derived Inflow and Infiltration)

$RDII = \text{Catchment Area} \times \text{Extraneous Flow Design Allowance}$

(Extraneous Flow Design Allowance as noted in the Water and Wastewater Master Servicing Plan)

2. Design Dry Weather Flow (DWF)

$DWF = \text{Average Sanitary Flow} + \text{Dry Weather Infiltration}$

3. Design Peak Dry-Weather Flow (Peak DWF)

$\text{Peak DWF} = DWF \times \text{Peaking Factor}$

4. Design Wet-Weather Flow (WWF)

$WWF = DWF + \text{Inflow and All Infiltration (Dry Weather and Rain Derived)}$

5. Design Peak Wet-Weather Flow (Peak WWF)

$\text{Peak WWF} = \text{Peak DWF} + \text{Design RDII (Catchment Area} \times \text{Extraneous Flow Design Allowance)}$.

6. The peaking factors to be applied to the average flow rates such as to determine the peak flow rates are dependent on the type of development. If possible, existing data to be used over assumptions.

a) Residential – depending on population using Harmon Formula

b) Industrial, Commercial, and Institutional – expressed in equivalent population and combined with residential population, then using Harmon Formula.

C.1.2.2 Design Capacity

The design capacity of a gravity sewer shall be the maximum flow that can be carried by a sewer without surcharging when the sewer is full.

1. The capacity of a gravity sewer is designed to meet either one of the following:
 - a) The Peak WWF when it is located upstream of combined sewer overflow (CSO) storage or when no storage exists
 - b) The Peak DWF when it is located downstream of CSO storage (appropriately sized).
2. The design capacity of a gravity sewer is assumed to be over committed when it runs surcharged during Design Peak DWF, or when it runs surcharged during Design Peak WWF with a peak hydraulic grade line less than 1.8 metres below ground elevation where basements exist or could exist.

C.1.2.3 Average Dry Weather Flow

1. The designer shall perform the wastewater design flow calculations based on the design parameters provided, using population densities by development type and loads, as published in the most current version of *Niagara Region's Water and Wastewater Master Servicing Plan*. In all cases these parameters are to be compared to actual flows and confirmed/revised as necessary prior to start of preliminary design.
2. Individual studies may be required for special commercial establishments/areas, major commercial/tourism areas, special industrial areas, and major industrial areas

C.1.2.4 Peak Wastewater Flow Factor

1. The designer shall refer to the most current version of *Niagara Region's Water and Wastewater Master Servicing Plan* for peak flow factors.

C.1.2.5 Infiltration Allowance

1. Designers shall use an infiltration rate consistent with that provided in the most current version of *Niagara Region's Water and Wastewater Master Servicing Plan*.

C.1.2.6 Flow Velocities

1. The maximum velocity shall not be greater than 3.0 m/s with the pipe flowing full, the minimum velocity is preferred to be 1.0 m/s and shall not be less than 0.60 m/s with average dry weather flow and is preferred to be above 1.0 m/s during Peak DWF.
2. Oversized sewers shall not be used in an attempt to justify using flatter slopes. The pipe diameter and slope shall be selected to obtain the greatest practical velocities to minimize solids settling.

C.1.2.7 Bedding and Backfill

1. Refer to General Section – Civil.

C.1.2.8 Rehabilitation of Existing Sewers and Maintenance Holes (Liners)

Where existing sewers are to be rehabilitated the following shall be required:

1. Maintenance hole rehabilitation shall incorporate corrosion protection and leak tightness against external ground water pressure.
 - a) The amount of time that a maintenance hole is out of service shall be minimized and the proposed bypass pumping plan shall utilize sufficient capacity to accommodate the design Peak WWF. The proposed bypass plan shall be submitted to Niagara Region for review and approval prior to implementation.
 - b) Condition assessments shall, at a minimum, be according to the most current version of the National Association of Sewer Service Companies' Pipeline Assessment Certification Program (NASSCO PACP).
 - c) Material and application specifications for grout shall be adequate to ensure a sound substrate on which to install the liner.
 - d) Specifications for liner properties shall require that the liner meet minimum standards for thickness, structural strength and elasticity and chemical resistance as outlined in *Niagara Region's Water and Wastewater Services Specification for Maintenance Hole Rehabilitation*.
 - e) Minimum requirements for quality control and liner testing shall be specified.
 - f) The rehabilitation design submission shall be stamped by a professional engineer licensed to practice in the Province of Ontario.
2. In the case of structural lining of existing sewers, the designer shall require that the proposed structural liner submission include calculations and measures as follows:
 - a) The amount of time that the sewer is out of service shall be minimized and the proposed bypass pumping plan shall be sized to accommodate the full Peak WWF as per the updating design. The proposed bypass plan shall be submitted to Niagara Region for review and approval prior to implementation.
 - b) CCTV inspections shall at a minimum, be according to the most current version of NASSCO PACP.
 - c) Material and application specifications for grout shall be adequate to ensure a sound substrate on which to install the liner.
 - d) Specifications for liner properties shall require that the liner meet minimum standards for thickness, structural strength and elasticity, and chemical resistance.
 - e) Minimum requirements for quality control and liner testing shall be specified.
 - f) The liner design submission shall be stamped by a professional engineer licensed to practice in the Province of Ontario.

C.1.3 System Layout

C.1.3.1 Location of Trunk Sewers

1. All new trunk sewers shall be located within the road allowance.

C.1.3.2 Pipe Depth

1. The top of the trunk sewer pipe shall be at a sufficient depth that it does not conflict with local infrastructure, where it can accept gravity flow from the area it services and such that the pipe contents are not susceptible to freezing.

C.1.3.3 Service Connections

1. Sewer services from residential, commercial, industrial, institutional and community facilities shall be connected to the nearest local area municipal sewer and not the Regional trunk sewer.

C.1.4 Pipe Material

1. The preferred pipe materials for trunk sewers are polyvinyl chloride (PVC) and reinforced concrete pipe (RCP). For areas where hydrogen sulfide is present or potentially created in the piped system, PVC is the preferred pipe material.
2. The designer shall determine the best pipe material for use depending on the application. Other materials may be considered provided that the designer provides sufficient justification for their use. If HDPE pipe is considered, only grey colored pipe is acceptable.
3. The designer shall include as part of the pre-design report the reasons for the selection of the proposed pipe material for the project. Where alternative materials are acceptable, the designer shall indicate this in the report and include a full life-cycle cost/benefit analysis of all the acceptable alternatives.
4. Prior to comparisons of pipe materials, the designer shall use commercially available software or other design techniques, to determine the appropriate class of pipe required.

Pipe Specification

Material	Joint Type	Specification
Polyvinyl Chloride	Gasketed Bell & Spigot	Maximum dimensional ratio – DR 35 CSA B182.2, OPSS 1841
Reinforced Concrete Pipe	Gasketed Bell & Spigot. Maximum joint deflection – 13 mm.	CAN/CSA A-257, OPSS.MUNI 1820; registered with Ontario Concrete Pipe Association (OPCA)
High Density Polyethylene (Trenchless Crossings Only)	Butt fused	AWWA C906 (grey in colour)

C.1.5 Maintenance Holes

All maintenance holes shall be designed to eliminate heaving/lifting and other movement and to prevent infiltration, based on the following criteria:

1. All maintenance holes shall conform to the *Ontario Provincial Standard Specifications (OPSS's)* and *Ontario Provincial Standard Drawings (OPSD's)* and *CAN/CSA A-257* except where another more stringent requirement is presented herein.
2. At maintenance holes where pipe sizes change from a smaller pipe size to a larger downstream pipe size, the obvert elevations of each pipe shall be matched. It is not permissible for the downstream pipe size to be designed to be smaller than the upstream pipe size.
3. Drop maintenance holes shall be provided where the invert elevation of a sewer entering a maintenance hole is 0.9 m above the invert of the outlet sewer.
 - a) Maintenance holes with internal drops will be designed to accommodate person access. Internal drops are preferred to external drops due to servicing issues with external drops. Vortex units, drop bowls or approved equivalents shall be considered for maintenance holes requiring internal drops.
 - b) The drop pipe shall be one nominal size smaller than the wastewater main.
 - c) The economic feasibility of providing deeper wastewater mains versus excessive invert drops, drop maintenance holes, or excessively steep benching shall be ascertained prior to finalizing the design.
 - d) Prefabricated drops internal to the maintenance hole are only permitted on 1500 mm diameter or larger maintenance holes.
 - e) Where the maintenance hole depth exceeds 5m, safety grating must be provided. Additional safety gratings must be provided every 5m as appropriate. The minimum maintenance hole diameter in such instances shall be 1500 mm.
4. When the rate of flow and the depth of the drop are of such a magnitude that there is potential for significant entrainment of air, then the drop shaft and lower connection shall be designed to provide for release of the entrained air and ventilation of the drop shaft.
5. Where significant sections of wastewater mains are provided with watertight covers at access maintenance holes, extended vents may be required which shall be determined by the designer on a case-by-case basis. The need for odor control shall be assessed in all vent locations.
6. Wherever possible, the designer shall avoid placing maintenance holes in low-lying areas. Locating maintenance holes in low-lying areas will only be accepted where no other option is available and in such locations, the top of the maintenance hole and lid shall be watertight and above the expected water level during a 10-year rain event.
7. Maintenance holes shall be provided with monolithic bases and watertight joints. Adjustment units, as per OPS, shall be provided for grade adjustment(s).

8. Tee maintenance holes may be used for wastewater mains 1200 mm or larger in diameter.
9. For institutional, commercial and industrial establishments, an inspection maintenance hole must be placed immediately adjacent to the property line for access to the service connection in accordance with the *Niagara Region Sewer Use Bylaw* (see *Niagara Standard Drawing (RSD S001-R01)*).

C.1.6 Forcemains

C.1.6.1 General

1. Forcemains shall be designed to withstand maximum operating pressure plus all surge and transient pressures and expected vacuum conditions without consideration for benefit provided by air/vacuum valves. That is to say, forcemains shall be designed as if all air/ vacuum valves are non-functional.
2. Transient analyses shall be part of the engineering design scope for all forcemains, and shall take into account the number and timing of the pump cycles to which the main(s) will be subjected.
3. A hydraulic transient analysis shall be undertaken as part of the design process considering the worst-case failure scenario involving the most critical pump and forcemain-in-service combination. The analysis will be completed using hydraulic models based on the final sizes and layout of pumps and forcemains including locations of air/vacuum release valves.

Based on the hydraulic transient analysis, provide devices, if necessary, to protect the forcemain such as, but not limited to, air/vacuum breaker, surge valves, surge tanks, etc. Hydraulic transient analysis shall be re-performed for any change in the forcemain material, class, alignment, or profile.

4. Wherever feasible, the designer shall design forcemains' profiles such that they rise continuously from the pumping station to the termination point. Ideally, local high points or low points shall be avoided. Under special cases, with the approval of Niagara Region, air valves will be permitted at local high points in the profile if the depth of the forcemain is impractical and tunneling techniques have been evaluated and discounted. Combination air valves shall be used only where shown to be required to protect pipe from vacuum. When combination air valves are used, the designer shall assess the need for and, if necessary, provide for removal of the inlet air prior to the forcemain outlet.
5. As reviewed on a case by case basis, all significant low points in the forcemain shall be equipped with drain chambers for maintenance.
6. For new construction, wherever possible, consideration should be given to provide redundant pipes/ conduits/ casings for pipeline crossings of major roads or waterways contingent on associated risk of failure.
7. Consideration should be given during design of critical trenchless crossings to provide provisions for cleaning and maintenance.

8. Forcemains shall be pressure-tested to zero leakage.
9. Common/shared forcemains are not permitted.

C.1.6.2 Forcemain Pipe Material

The designer shall comply with the following requirements.

1. In determining the suitable pipe class to be used, live load, dead load, soil type and trench conditions shall be considered in the calculation. The pipe manufacturer's recommendations shall be incorporated into the design.
2. The following pipe materials are acceptable for forcemains.
 - a) Standard PVC
 - b) Fusible PVC
 - c) Molecularly oriented PVC (PVCO)
 - d) Concrete pressure pipe (CPP)
 - e) HDPE (Trenchless Water Crossings only)
 - f) Stainless Steel (304/304L-North American) inside facilities and chambers

Forcemain Pipe and Fitting Materials

Material	Joint Type	Specification	Fittings
Polyvinyl Chloride	Gasketed Bell & Spigot	AWWA C900 & C905, CSA B137.3	PVC: AWWA C900, C905, C907, CSA B137.2, B137.3
Fusible Polyvinyl Chloride	Fused joints	AWWA C900 & C905, CSA B137.3	PVC: AWWA C900, C905, C907, CSA B137.2, B137.3
Molecularly-oriented PVCO	Gasketed Bell & Spigot	AWWA C909	PVC: AWWA C900, C905, C907, CSA B137.2, B137.3
Stainless Steel	Welded	ASTM A312, Grade 304/304L or 316L, minimum Schedule 10S	Stainless Steel, Type 304/304L or 316L, ASTM A403
High Density Polyethylene (Trenchless Crossings Only)	Butt fused	AWWA C906	HDPE - AWWA C906 Electrofusion

Material	Joint Type	Specification	Fittings
Pre-tensioned Conc. Cylinder Pipe	Gasketed Bell & Spigot with wrap-around cement mortar diaphragms	AWWA C303	Concrete – AWWA C303
Pre-stressed Concrete, Lined Cylinder Pipe	Gasketed Bell & Spigot with wrap-around cement mortar diaphragms	AWWA C301 & C304	Concrete – AWWA C301 & C304
Pre-stressed Concrete, Embedded Cylinder Pipe	Gasketed Bell & Spigot with wrap-around cement mortar diaphragms	AWWA C301& C304	Concrete – AWWA C301 & C304

C.1.6.3 Thrust Restraint

1. Forcemain thrust restraints shall be designed to withstand the maximum operating pressure from the transient analysis. Adequate thrust restraint must be provided to account for all flow conditions.
2. All pipe and appurtenances shall be protected with approved mechanical thrust restraints. Concrete thrust blocks shall not be allowed for buried applications.

C.1.6.4 Pipe Size

1. Forcemains shall be sized to have a flow velocity in the range of 1.0 m/s to 2.0 m/s, with the lower limit being used for the initial phase.
2. The minimum size for forcemains shall be 150 mm diameter.

C.1.6.5 Pipe Depth

1. Forcemains shall have a minimum 2.0 m cover. Where 1.5m depth is not attainable at a specific location, the forcemain shall be completely encased with a minimum of 50mm of polystyrene insulation wrap. Insulation thickness shall be designed to provide a minimum time to ice development, after flow stoppage, of 48 hours.
2. In areas where minimum cover cannot be achieved, special provision(s) shall be considered to protect pipe from live loads..
3. Forcemains shall be deep enough to provide sufficient head room in valve chambers.
4. Under open ditch or unimproved roads, the minimum cover shall be provided to allow for future road improvements or lowering of the road profile.

C.1.6.6 Bedding and Backfill

1. Refer to General Section – Civil.

C.1.6.7 Valves

1. All air valves are to be suitable for use with wastewater and shall be low-pressure double acting types.
2. Air release valves shall be provided at all significant high points on forcemains. Air release valves are to be located in chambers where ever feasible and shall be provided with isolation valve and vent lines that include a duck-billed check valve to ensure that the vent piping is always clear. All air release valves are to be on a “T” connection that is to have a diameter of at least 1/3 of the main line diameter and no less than 150mm diameter. As reviewed on a case by case basis, on PVC forcemain pipe 300mm diameter or less, the Region may permit the installation of an air valve on a stainless steel service saddle without the need to transition to stainless steel inside the chamber.
3. Air lines shall include a quick connect union for easy removal of air valve.
4. Air lines shall include a drain tee complete with duckbill type backflow prevention to ensure
5. Air valves shall be located on roadway shoulders and out of intersections.
6. Direct-buried valves are prohibited.
7. The minimum drain valve size shall be 150 mm. The valve shall have operator stem extended to the chamber roof in order to be operable from the surface. Drain pipe shall include an appropriate camlock fitting for connecting a hose to the surface.
8. Chambers, pits or access holes containing valves, blow-offs, meters or other such appurtenances to the wastewater system, shall not be located in areas subject to flooding or in areas of high groundwater.

C.1.6.8 Corrosion Prevention

1. As a minimum, buried metallic components including stainless steel shall be protected from corrosion using three-part petrolatum tape meeting ISO 9001 standards.
2. All components of the corrosion protection shall be supplied by the same manufacturer/ supplier.

C.1.6.9 Tracer Wire

Refer to General Section – Civil.

C.1.6.10 Forcemain Outlets / Transition Maintenance Holes

The designer shall make provisions for a smooth transition from forcemain pressure flow to gravity sewer flow.

1. All sewage forcemains must terminate in a transition maintenance hole on a gravity sewer. The transition maintenance hole must permit a smooth flow transition to the receiving gravity sewer maintenance hole. The forcemain shall enter the transition maintenance hole at a point not more than 0.3 m (1 ft) above the invert.

2. No other gravity sewers or laterals shall enter the transition maintenance hole.
3. The gravity main from the transition maintenance hole to the next maintenance hole shall be at least one size larger than the forcemain and shall have sufficient capacity for all design flows.
4. In addition to using Type HS concrete, forcemain transition maintenance holes shall be constructed from concrete made with a crystalline admixture (Kryton, Xypex or approved equal) or have an acceptable corrosion protective coating.
5. Turbulence in the outlet of the transition maintenance hole must be minimized.

C.2 Wastewater Pumping Stations

C.2.1 Design Vision

Wastewater pumping stations shall provide reliable, safe, energy efficient and low maintenance operation with low visual impact to the surrounding community.

1. Region preference is to house electrical equipment in outdoor MCCs and control cabinets protected from the elements inside a bus shelter-type enclosure.
2. Niagara Region wastewater pumping stations shall use submersible pumps unless specified otherwise in the Request for Proposal or unless a strong case can be made for a dry well / wet well configuration by the designer.
3. Wet wells shall be designed to minimize turbulence, odour problems, frequency of maintenance, and to maximize pump life.
4. DWFs, WWFs and all operational requirements shall be confirmed prior to start of any preliminary design.
5. Pump stop levels should be designed to minimize the volume of sewage remaining in the wet well after each pump cycle.

C.2.2 Basis of Design

Pumping station configuration shall be designed to provide the most efficient layout of pumps, equipment and piping with consideration for ease of access and maintenance.

1. All pumping station designs, both new stations and retro-fits, shall aim at eliminating (or minimizing where elimination is not feasible) the need for confined space entries into classified areas.
2. Pumps shall be selected based on the most optimal combination of pump efficiency, and full life-cycle (capital, operating and maintenance) costs. A spare pump is to be included in the design for stations without emergency overflows and that are only equipped with 2 pumps (1 duty, 1 standby)

C.2.2.1 Wet Wells

Wet wells shall be designed with the following considerations:

1. Wet wells shall be designed to meet Hydraulic Institute guidelines and to prevent dead zones and debris accumulation. Slope of floor benching shall be preferred 2:1 and a minimum 1:1 (other than the pump footprint).
2. Wet wells shall be designed with a minimum 500mm freeboard from the last duty pump start level to the invert of the inlet sewer. As reviewed on a case by case basis, additional emergency storage may be required for stations that are not equipped with an emergency overflow and higher risk. This requirement to be identified during the pre-design stage.
3. The depth of the wet well shall be sufficient to ensure adequate control bands for each pump within a maximum of six (6) starts per hour.
4. Pump run time shall be a minimum of 5 minutes at Design DWF. Wet well fill time shall be a maximum of 30 minutes at Design DWF.
5. As reviewed on a case by case basis, means for wet well cleaning must be provided. Provide a 19mm diameter yard hydrant complete with approved RPZ backflow preventer located near the wet well for wash down.
6. Access hatches for entry, equipment/ instrument removal, and maintenance must be provided. Hatches will have safety grating under the lid that need to be opened separately from the lid. All access hatch self-draining trough drains to be piped to the exterior (preferred) or to chamber sump.
7. Wet wells shall be water tight with zero visible leakage.
8. Other than pumps, only corrosion resistant concrete and stainless steel (304/304L) are permitted in wet wells.
9. The wet well roof (where hatches are located) shall be at least 200 mm above the 100-year regional flood line.

C.2.2.2 Wet Well Ventilation

1. Declassification of classified areas by means of ventilation will not be accepted.
2. Ventilation of wet well shall meet the following requirements.
 - a) Passive ventilation is required for all wet wells complete with Schedule 10S stainless steel 304/304L gooseneck outlet and screen. All ventilation ducts in wet well shall be stainless steel.
 - b) For entry into the wet well for maintenance and/ or operational functions, the preferred method of providing ventilation is to use portable fans implemented by operations staff.
 - c) The requirement for a positive forced air ventilation fan and odour control shall be reviewed during pre-design and considered on a project specific basis.
 - d) Ventilation fan shall be explosion proof and corrosion resistant.

- e) Ventilation exhausts shall be directed away from nearby properties as much as practical to reduce the chance of nuisance odours.

C.2.2.3 Valve Room Ventilation

For larger stations with superstructures where a valve room is required, the following shall apply.

1. Permanent ventilation equipment and duct work is required.
2. Provide positive ventilation system complete with motorized intake and exhaust dampers and fans with automatic and manual control.
3. It is not permissible to use ventilation equipment to de-rate valve room space.

C.2.2.4 Electrical

Electrical requirements for sewage pumping stations shall be as follows.

1. All electrical equipment shall be designed appropriately for the area classification. Where possible, for ease of service and operation, equipment must be installed in an unclassified area.
2. The designer shall ensure there are two 20A ground fault interrupt (GFI) external electrical outlets located close to the wet well and valve chamber access point.
3. Pumps with temperature and leakage sensors tied to the SCADA alarm system are required.
4. The electrical utility box shall be compact and low profile to complement the aesthetics of the location.
5. For a submersible pumping station where the electrical cabinet is located in in a bus shelter, the cabinet shall be sized, oriented and located to permit safe maintenance work.
6. A junction box equipped with terminal strip shall be provided on the exterior of the station to facilitate changes of the float regulators.
7. A separate junction box is required for pump power supply and to enable the removal and installation of the pump.

C.2.2.5 Odour Control

1. All sewage pumping stations shall be designed to minimize the escape of odours from the wet well. The designer shall provide engineering calculations of potential for hydrogen sulfide generation in the forcemain and provide recommendations to prevent generation of odours and for odour control.
2. Region preference for odour control is the use of canister style carbon filters on vent pipe.

C.2.2.6 Wet-weather Storage and Overflows

The need for wet-weather storage at pumping stations for both new stations as well as retro-fits is to be identified by the designer during the pre-design stage.

1. Sewage Storage/Overflows must discharge back to the wet well (preferred), to a water body, municipal drain or to a storm sewer. Discharge to a storm water detention pond is not permitted. Overflow lines shall be equipped with a backflow preventing valve.
2. The discharge from overflows is required to be monitored and measured for compliance reporting to the MECP.
 - a) The design shall incorporate a method to measure the time, duration and the quantity of overflowed sewage to meet this requirement.

C.2.2.7 Sewage Pumping Station Classification

	Pumping Station Capacity	Type	Wet Well Storage Capacity	Number of Primary Duty Pumps Required	Standby Pump Requirement	Type of Drives	Standby Power	Minimum Lot Size
1	Inflow: 0 to 120 L/s.	Submersible pumping station with single wet well and bypass inlet maintenance hole. Outdoor sound-attenuating enclosure for the standby generator. Outdoor control panel and MCC complete with bus type shelter.	Storage requirements to be discussed on a project-specific basis.	One or more pumps with a combined capacity equal to design flow. Pumping system shall be designed for the most efficient configuration under average day flow conditions.	One standby pump rated at the same capacity of the largest unit.	Soft starters are preferred. VFDs only as approved by Niagara Region.	Emergency generator sized to handle design flow and all other essential loads required.	25m x 25m
2	Inflow greater than 120 L/s.	Submersible pumping station with divided wet well. Outdoor sound-attenuating enclosure for the standby generator. Outdoor control panel and MCC complete with bus type shelter or superstructure for housing controls and MCC.	Storage requirements to be discussed on a project-specific basis.	Two or more pumps equally sized pumps with a combined capacity equal to design flow. Pumping system shall be designed for the most efficient configuration under average day flow conditions.	One standby pump rated at the same capacity of the largest unit.	Soft starters are preferred. VFDs only as approved by Niagara Region.	Emergency generator sized to handle design flow and all other essential loads required.	40m x 40m

C.2.3 Facility Layout

C.2.3.1 Outdoor Bus Shelter

1. For smaller pumping stations electrical equipment and panels are to be located inside a bus shelter type structure.
2. Bus Shelters shall be either Vista, Avanti or Contemporary styles as supplied by DayTech Limited or approved equal.
3. Shelters shall be enclosed on all four sides with the exception of the entrance complete with interior LED lighting.
4. Floor elevation must be at least 200 mm above regional 100-year flood line
5. Shelter layout shall look to provide sufficient space for complete servicing, removal, and replacement of all equipment without impacting operation of the facility.

C.2.3.2 Control Building

1. For projects where a building is required, provide a building to house electrical equipment and pump controls, mechanical ventilation equipment and lighting equipment.
2. Motorized intake and exhaust louvers shall be provided for ventilation requirements.
3. Control buildings shall be equipped with wheel chair accessible washrooms.
4. Floor elevation must be at least 200 mm above regional 100-year flood line.
5. Consideration shall be given for possibility of future upgrades/expansions of the pumping station in order to maximize the utilization of the available space of the property.
6. Building layout shall look to provide sufficient space for complete servicing, removal, and replacement of all equipment without impacting operation of the facility.

C.2.3.3 Site Requirements

1. A paved access driveway and parking area shall be provided with adequate space for access and maneuvering by Region's crane truck, sewage vacuum trucks and fuel delivery trucks. Access for sewage hauling tanker trucks shall also be considered on site or along the road in front of the station.
2. Site shall have proper drainage features in order to provide for the safe, economic and efficient utilization and operation of the station and its property.
3. All site grading shall be designed to promote drainage from site and not cause adverse effects to surrounding properties.

C.2.4 Process Equipment

C.2.4.1 Pumps

Pumps shall be provided with the following requirements.

1. Pumps shall be high efficiency, explosion-proof, submersible, a non-clog impeller type suitable for fluid to be pumped.
2. Vibration and harmonic analysis must be conducted for pumps if installed in dry wells.
3. Pumps shall be equipped with thermal and leak detection devices.
4. Pumps must be removable from the surface utilizing guide rails.
5. Lifting equipment with appropriately placed davits shall be provided for all pumps that cannot be accessed by the Region's crane truck.
6. Sumps in valve chambers that cannot drain to the wetwell by gravity shall be equipped with a sump pump.

C.2.4.2 Valves

1. All valves are to be installed in a horizontal piping configuration.
2. Valves must be located in a separate water tight valve chamber or valve room. Valves located in the wet well are not acceptable.
3. All valves shall be supplied with fully restrained dismantling coupling.
4. An air release valve is to be provide on the station's main discharge header installed on a tee connection that is to have a diameter of at least 1/3 of the main line diameter and no less than 150mm diameter. Piping to be redirected to the wetwell.

C.2.4.3 Process Piping and Fittings

In the design of sewage pumping station piping, the designer shall comply with the following criteria.

1. All appurtenances and connectors shall be corrosion-resistant and compatible with the piping material.
2. Piping layout shall be designed with wye's and not tee's.
3. Flushing connections to facilitate cleaning of plugged lines or pumps shall be provided. Flushing connections shall be a minimum of 50mm diameter.
4. A means for draining the forcemain into the wet well is required. Drain connection is to be located downstream to the isolation valve on the forcemain.
5. A piped bypass system around the flowmeter shall be considered for stations with a peak dry weather flow greater than 50L/s in order to permit maintenance on the flowmeter while maintaining station operation.

C.2.4.4 Surge Protection

It is preferable that the designer address flow velocities and pressures within the lift station piping and forcemain to eliminate the possibility of pressure transients and dangerous surge pressures. However, if, given the profile of the forcemain and pipe sizes are such that surges cannot be eliminated, the designer shall include a provision for adequate

surge control on the station's main discharge header. The designer must review this on a project by project basis.

C.2.4.5 Instrumentation

As a minimum, the following instrumentation shall be provided:

1. Wet well level ultrasonic transmitter.
2. Wet well operating backup floats, high level float and overflow float.
3. Flowmeter on forcemain discharge header.
4. Flowmeter on overflow system
5. Pressure transmitter on each forcemain discharge header. A secondary branch connection with quick connect from the pressure transmitter for a pressure gauge
6. Flood floats to be provided in all chambers near the sump.
7. Pump power monitor.
8. Provide temperature, smoke and fire alarms in all buildings.

C.2.5 Process Pump Controls

1. Operation of the pumps is to be controlled by the level transmitter connected to the station Programmable Logic Controller (PLC) or remote programmable unit (RPU).

C.2.6 Wet Well / Dry Well Pumping Stations

In rare instances where the design calls for a wet well / dry well-type pumping station, the following provisions shall apply.

1. Dry well shall be physically separated from electrical room, which shall be a non-classified area.
2. Pumps are to be supplied with downstream air valves located prior to check valves to ensure priming. Suction pipe cleanouts shall be provided.
3. Wet well suction inlets shall be bell-mouth (flared) type.
4. A surge pressure relief valve with relief pipe extending from the discharge header through the dividing wall and into the wet well above the TWL. Orientation and routing of this relief pipe shall allow the pipe to drain by gravity to the wet well.
5. Flood floats shall be provided in the dry well.
6. Pressure gauge connections shall be provided on each pump suction line.
7. Permanent dry well ventilation equipment and duct work is required. Provide positive ventilation system in the dry well, complete with motorized intake and exhaust dampers and fans with automatic and/or manual control.
8. It is not permissible to use ventilation equipment to de-rate drywell space.

C.3 Wastewater Treatment Plants

C.3.1 Design Vision

Niagara Region's goal is to produce effluent from each of its wastewater treatment plants that meets the effluent quality limits and objectives stipulated in each Environmental Compliance Approval (ECA).

Wastewater treatment plants and upgrades shall be designed to provide for reliable, safe, energy/cost efficient and low maintenance operation while minimizing impacts on the surrounding community.

Internal plant operating objectives (working levels) identified in this section have been developed for various operational parameters for Niagara Region's Wastewater Treatment Plants.

Treatment plants shall have sufficient backup controls and devices to allow for effective maintenance of all equipment without upset to the process or impacts on final effluent or biosolids quality.

C.3.2 Facility Layout

C.3.2.1 Process

In designing the layout of wastewater treatment plants, consideration shall be given for future expansions of the plant to its ultimate site capacity in order to maximize the utilization of the available space of the property.

1. Works must be designed for proper flow splitting at each step in the overall treatment train. Interconnections between equivalent treatment processes from different stages of overall plant development shall be incorporated into the design wherever possible.
2. Facility layout shall provide sufficient space and connectivity to allow for complete servicing, removal, and replacement of all process equipment without impacting operation of the facility.

C.3.2.2 Site Requirements

In designing the layout of wastewater treatment plant sites, consideration shall be given for site access future expansions of the plant to its ultimate site capacity in order to maximize the utilization of the available space of the property.

1. A paved access driveway and parking area shall be provided with adequate space for access and maneuvering by sewage hauling tanker trucks and fuel and chemical delivery trucks.
2. Site shall have proper drainage features in order to provide for the safe, economic and efficient utilization and operation of the plant and its property.
3. All grading shall be designed to promote drainage from site and not cause adverse effects to surrounding properties.

C.3.3 Treatment Processes and Equipment

C.3.3.1 Process and Equipment Redundancy

The designer shall consider multiple parallel treatment trains for each major process treatment step in the overall plant.

C.3.3.2 Inlet Works

The inlet works shall be housed in a building and designed for ease of operation for the removal of collection bins, process equipment, and cleanup of the facility so as to promote a positive working environment for the operators.

At a minimum, it shall include the following.

1. Inlet works shall be sized to handle Design Peak WWF into the facility
2. Automatically cleaned screens shall be provided at all headworks. Preference shall be given to multi-rake, travelling bar screens.
3. An automated operable bypass weir gate and associated channel/piping for emergency operation shall be provided.
4. A screening compactor for the compaction of screening waste material shall be provided. Generally, the same manufacturer shall be selected for both screens and compactors to ensure compatibility.
5. Grit removal equipment shall be provided.
6. Grit and screenings shall be deposited in separate bins.
7. All wastewater originating from the grit cyclone and classifier and compactor shall be piped for return to the plant process stream.
 - a) Grit removal area and grit bins shall be designed and sized to minimize the manual labour involved with moving bins.
 - b) Preference is to have the bins as close to an exterior door and driveway as possible and in the correct orientation to allow the bin removal truck access to the bins.
8. Grit removal shall utilize aerated grit tanks or vortex grit separators without the use of air lift pumps, with preference given to aerated grit tanks. Note: Vortex grit separators are only suitable when footprint is a limitation.
9. Odour control with appropriate ventilation system shall be designed to minimize the odour level in the inlet works working area.
10. Detection equipment and instrumentation is required for monitoring the operation of process equipment with a fail-safe feature that would be employed in the presence of combustible gases.
11. Parshall Flumes (preferred) shall be provided in the influent and by-pass channels for flow measurement.

12. A means for the interception and removal of grease at the headworks shall be provided as well as a separate bin for the temporary storage of grease.
13. Where a septage receiving station is required, it shall be located at the head of the plant and shall include the following requirements:
 - a) Be capable of receiving hauled sewage loads from a variety of truck sizes.
 - b) An actuated valve to allow for the disposal to be directed to either the headworks or to the digesters, or separate receiving locations as dictated by location and space requirements.
 - c) Septage receiving stations shall be provided with a kiosk for the deposit and storage of hauled sewage manifests, a refrigerator for storage of collected samples, a writing area to allow completion of manifest information, an electric space heater, and a wash-up sink for disposal of samples and hand washing.
 - d) There shall be no classifications in this area and it shall be designed for human occupancy.
 - e) Septage receiving stations shall be laid out so that:
 - There is adequate room for septage hauling trucks to effectively maneuver
 - Spills will be contained to the area surrounding the entire vehicle and hose connection, and
 - The entire receiving area can be hosed down to a CB connected to the influent channel. See C.3.3.9 for additional requirements of containment area.

C.3.3.3 Primary Clarification

The designer shall provide a minimum of two primary clarifiers, sized such that with one clarifier out of service, the remaining capacity is equal to or more than the Design DWF (ECA capacity). Design Hydraulic Retention Time (HRT) shall be no more than 2 hours for low ADF days. Design shall include for even flow splitting between clarifier units. Surface scum collector troughs shall be provided.

C.3.3.4 Aeration

Aeration system design shall include the following features:

1. The designer shall provide a minimum of two aeration tanks.
2. Systems shall utilize high efficiency fine bubble aeration.
3. Where applicable, aeration tanks shall be designed assuming a Plug Flow reaction and to have step feed capability.
4. The aeration system is required to meet the minimum oxygen concentration and mixing requirements. Aeration systems shall be capable of achieving, at any point in the aeration tanks, a minimum dissolved oxygen (DO) concentration of 2.0 mg/L at all

times. Aeration systems shall also be capable of providing sufficient mixing to maintain all mixed liquor solids in suspension for each aeration zone, with an aeration zone defined as an area of diffuser density different from a neighboring zone.

5. A flow measuring device shall be provided at the main air header. For all branch air headers, each branch shall be provided with a flowmeter, an isolation valve and a pressure gauge. Isolation valves shall not be used as balancing devices. Any diffuser zone will need a separate device from the isolation valve to balance airflow, if required by the design. All flowmeters shall include a local readout for flow, located so that operators at ground/floor level can read flow.
6. The designer shall provide required field instrumentation (including DO analyzers) for the measuring of dissolved oxygen levels in each tank at mid-tank and at end of tank (minimum 2 DO analyzers per tank).
 - a) The field instrumentation and related control system shall be tied to a fully automated dissolved oxygen (DO) control system which links actual DO level to blower(s) capacity and will automatically vary the air output from the blower(s) in direct response to measured DO, with the intent to keep the DO sufficiently above 2 mg/L throughout the aeration process. DO control shall utilize a step control system whereas the air rate is increased/decreased at DO setting levels above the required 2 mg/l. Step control logic to be adjusted and verified to work at time of testing/commissioning prior to functional run tests beginning.

C.3.3.5 Secondary Clarification

1. The designer shall provide a minimum of two secondary clarifiers, sized such that with one clarifier out of service, the remaining capacity is more than the Design DWF (ECA capacity).
2. Sludge return capacity shall be designed for 100% return sludge capacity and all activated sludge flows, both return and waste, shall be metered and recorded.
3. A surface scum collector trough shall be provided.
4. Scum collector shall be fully and easily adjustable by hand with minimal tools.
5. All metal parts in clarifiers are to be stainless steel.

C.3.3.6 Sludge Pumping

1. Sludge pumps, including raw sludge pumps, return activated sludge (RAS) pumps and waste activated sludge (WAS) pumps, must be suitable for handling sludge and gritty material.
2. Each clarifier shall have a dedicated RAS pump.
3. RAS pumps are required to be sized to meet the full range of flow defined in the MECF Design Guidelines for Sewage Works.
4. An on-line sludge total solids (TS) meter shall be provided and tied into SCADA.

C.3.3.7 Effluent Disinfection

Current practice at Niagara Region is to disinfect plant effluent with liquid chlorine (sodium hypochlorite) followed by de-chlorination with injection of a second chemical. The objective is to have no presence of free chlorine in the final effluent at the outfall to the receiving stream.

C.3.3.8 Sludge Digestion

1. The primary digesters shall be circular reinforced concrete tanks with conical floors, with one sidewall access bulkhead into the digester for inspection and cleaning.
 - a) The exterior of the tank shall be complete with pre-cast concrete panel veneer or aluminum cladding.
 - b) An insulated fixed steel cover is required for the primary digester.
 - c) Mixing equipment shall be provided for the primary digester. Secondary to primary digester volume ratios shall not be greater than 1:1.
2. Secondary digesters shall be circular reinforced concrete tanks with conical floors with one sidewall access bulkhead into the digester for inspection and cleaning.
 - a) The exterior of the tank shall also be complete with pre-cast concrete panel veneer or aluminum cladding.
 - b) An insulated steel floating cover for secondary digesters.
 - c) A supernatant line, equipped with a flowmeter, shall be provided, and TS metering shall be required on all digested sludge lines leaving the secondary digester.

C.3.3.9 Sludge Loading Station

The sludge loading station shall be designed for minimum interference to the operation of the plant during the sludge loading operation.

1. Access to the sludge loading station shall be designed to permit trucks to enter and leave the station directly without backing into or out of the station. (i.e.: drive through access)
2. A fully curbed spill containment area shall be provided at the loading station with a catch basin in the middle of the containment area.
3. The containment area shall drain to a holding tank.
4. A hosing station shall be provided for the cleaning of spilled sludge off the truck or the containment area.
5. The sludge loading arm shall be heat traced and insulated as necessary on all outside pipe sections. Heat tracing shall be installed in conduit on the underside of the loading arm to allow for simple and easy inspection and replacement.
6. A lockable remote control at the sludge loading station must be provided for the starting and stopping of the sludge loading pump.

7. A magnetic flowmeter in a building or chamber shall be provided to measure the volume of the sludge being pumped into the truck.
 - a) An electronic readout at the sludge loading station is required to indicate the volume of sludge pumped into the truck.
 - b) The electronic readout shall be visible to the driver of the tanker truck.
 - c) Pumped volume data shall be date and time stamped and shall be captured and recorded by the SCADA system.

C.3.3.10 Sampling Stations

Automatic sampling stations are required to perform discrete or composite, flow proportional and time proportional sampling.

1. The sampler enclosure shall be weatherproof, corrosion resistant, insulated, and complete with forced air heater and thermostat, locking door and bolt down base.
2. The refrigerated sample compartment must be lockable.
3. The controller must be programmable with an LCD display.
4. In the event of a power failure, program settings and stored information shall be maintained by an internal lithium battery.
5. Samplers shall not be installed in classified environments.

C.3.3.11 Pressurized Effluent Water System

The designer shall provide a high pressure effluent water system where required as determined by operations staff for the cleaning of process equipment and general site maintenance.

1. The effluent water system shall consist of a minimum of two pumps and a hydro-pneumatic tank to maintain a preferable system pressure of 413kPa (60 psi), even when the pumps are not running. All effluent water needs to be screened/filtered to 500 micron size prior to pumping. Designer to use self-cleaning screens/filters.
2. The system shall be fully automatic with the pumps delivering the required flow and pressure at the furthest post yard hydrant of the effluent water system.
3. Yard hydrants shall be self-draining and non-freezing. Yard hydrants shall be installed above an engineered granular/geomembrane soakaway. Soakaway to be located below the frost elevation and above the higher seasonal ground water level.
4. Potable water may be provided with the same function if the effluent water cannot be used in a location, as determined by the operations staff. All potable water service to yard hydrants shall include a RPZ backflow preventer located near the potable water service entrance to the property. RPZ backflow preventers must be installed in a location to prevent freezing, flooding and mechanical damage with adequate space to facilitate maintenance and testing. RPZ backflow preventers must not be installed in a vault, pit or enclosed space. There shall be no type of interconnection between the

effluent water system and the potable water system. Drainage for backflow prevention assemblies shall be provided for all installations of RPZs to accommodate discharge during testing or draining of the unit and for RPZ relief valve discharges.

5. Where effluent water is used, a sign shall be permanently fastened at every new and existing hose bib, faucet, hydrant or sill cock located on the effluent water system.
 - a) The nameplate shall read 'Caution Non-Potable Water'.
 - b) Nameplates shall be of the lamacoid type.

C.3.3.12 Low Pressure Hot Water Heating Systems

Low pressure piping and hot water systems shall meet the following criteria:

1. The layout of piping shall provide an expansion and contraction allowance of 100°C in water temperature to ambient at a rated pressure of 860 kPa (125psi) or as required to meet system requirements.
2. All heating pipes shall be installed in such a way that all high points have air relief valves and all low points have drain valves and necessary piping/facility for drainage of full system volume.
3. Piping shall be installed so that there will be no interference with the operation or installation of equipment or other piping systems, ducts, etc.
4. Piping shall ensure noiseless water circulation.
5. Pipes shall not be routed over electrical panels/ transformers.
6. An appropriate location in the heating system shall be provided for the injection of chemical into the hot water system.
7. Balancing and flow control valves shall be provided on hot water return piping from each heating unit or equipment and on the supply and return of each primary and secondary circuit. Immediately after the system is started up and prior to being put into operation, the entire system is to be balanced.

C.3.3.13 Circulating Pump

1. Circulating pumps are to be centrifugal pumps or close coupled vertical in-line pumps.
2. Pump installations should include a shut-off valve, and suction guide in pump suction piping; and a combination check-balance-shut-off valve assembly on the discharge.
3. A pressure gauge shall be included at the discharge side of all pumps.

C.3.3.14 Boiler

1. Boilers heating systems shall consist of dual gas fired boilers and have a minimum energy rating of 85% efficiency.
2. All boilers shall use tube-in-tube heat exchangers (HX).

C.3.3.15 Instrumentation and Control

In addition to the requirements specified by the *MECP Guidelines for the Design of Sewage Works*, latest edition, the following shall apply.

1. Flow transmitters shall be provided on each raw influent stream, including hauled waste, final effluent, internal return or recycle lines, and side streams from sludge processing steps. The objective is to measure flow to and from all processes sufficiently to allow for an accurate flow balance to be performed across the entire plant.
2. Total solids (TS) meters and flow transmitters shall be provided on all primary sludge, secondary sludge (RAS), and waste sludge (WAS) lines. The objective is to measure all process flow sufficiently to allow for an accurate solids mass balance to be performed across the entire plant.

C.3.4 Energy Efficient Treatment Plant

1. In addition to the following, the designer shall review Section A of this manual for general guidelines pertaining to energy efficient design.

C.3.4.1 Primary Treatment

1. The designer shall consider the potential use of chemically enhanced primary treatment (CEPT) with the goal of reducing energy costs. The designer is to perform a full cost-benefit analysis of this and other options.

C.3.4.2 Anoxic Selectors

1. Anoxic zones shall be considered for all tanks to improve settling and to allow for denitrification to reduce process aeration costs.

C.3.4.3 Return Activated Sludge Pumps

1. RAS pumps shall be provided with variable frequency drives and controllers that pace flow based on wastewater flow rate to allow for maximum turndown and energy savings.

C.3.4.4 Disinfection

1. The designer shall evaluate the cost/benefit of UV versus chemical disinfection for the application. If ultraviolet (UV) irradiation is recommended for disinfection, only low pressure systems offering the highest UV efficiency shall be used.

C.3.4.5 Digestion

The largest energy users in anaerobic digestion include sludge heating and sludge mixing. The designer shall consider the following opportunities to reduce energy use.

1. The cost/ benefit of alternative mixing systems with respect to energy consumption and life-cycle costs shall be considered, including newer technologies (e.g., linear motion mixers). On-off timers for hydraulic mixing systems shall be provided to reduce energy costs, while maintaining performance with slow settling anaerobic biosolids.

2. The thickening of WAS and/or primary sludge to maximize the sludge feed thickness to digestion shall be considered, resulting in lower heating costs and a smaller digester footprint for mixing.
3. Boilers with the ability to utilize both natural and digester gas shall be provided.
4. Appropriate gas metering is required to monitor the performance of gas production.
5. An incoming sludge solids meter and flowmeter shall be provided.
6. Sludge pre-conditioning technologies to maximize sludge stabilization and gas production should be provided.
7. The designer should provide a sludge-to-sludge heat exchanger to recover energy from the digested sludge (typically 35 degrees C in a mesophilic digester) by pre-heating the sludge feed (typically 10 to 20 degrees C).

C.3.4.6 Thickening and Dewatering

Low energy technologies (gravity belt thickener, rotary drum thickener, etc.) should be used to thicken WAS or primary sludge. Effluent water should be utilized, wherever feasible, for belt/ drum cleaning.

1. The total life-cycle cost benefit analysis should be performed and considered when selecting the preferred dewatering technology including power, labour, maintenance, cake dryness, solids capture, biosolids haulage and disposal.
2. When dewatering centrifuges are preferred, structure procurement documents to favour equipment with the lowest total power requirements.
3. Polymer systems should be designed to make down at the highest possible concentration (typically 1%) to minimize potable water consumption. Effluent water should be utilized for secondary dilution to the concentration required for the thickening or dewatering process (typically 0.2 – 0.5%).
4. Consideration shall be given to specifying automated sludge thickening and dewatering equipment.

C.3.4.7 Drying

The following opportunities for maximizing the energy efficiency of a drying facility should be considered.

1. Dewatering technologies and/or digester feed conditioning systems should be selected to maximize the dewatering cake solids concentration to drying (i.e., minimize the energy required for evaporation).
2. Opportunities to recover waste heat or energy should be considered (e.g., digester gas, jacket and exhaust heat from co-generation facilities, etc.) in the treatment plant to off-set the costs of natural gas.
3. The feasibility of solar drying to minimize fossil fuel use should be reviewed.

C.3.4.8 Energy Recovery

The designer shall review opportunities for digester gas energy recovery either through co-generation, micro-turbines or gas purification to natural gas quality for injection to the local grid or for use as vehicle fuel.

1. For any co-generation facility, jacket heat recovery shall be provided at a minimum, and potentially exhaust and jacket recovery shall be provided to allow heating of the feed solids to digestion without supplemental fuels.
2. Alternative digestion pre-conditioning systems shall be reviewed to maximize gas production for co-generation or purification.
 - a) For these systems, an energy balance evaluation (i.e., energy in vs. energy out) shall be completed to determine the effectiveness of the conditioning system.
 - b) Only conditioning systems that offer a net positive energy benefit shall be utilized.

C.3.4.9 Other Considerations

Other considerations for energy efficiency in preliminary treatment include the following opportunities:

1. Enclosed equipment and channels with dedicated draw-off to odour control unit may be utilized to reduce air changes required in the main building area.
2. Equipment with lower overall headroom requirements shall be selected to minimize building height and ventilation air volumes.
3. Areas having Class 1, Division 1 classifications shall be designed, where appropriate. The designer may consider a system with flexibility for lower ventilation rates during winter months.
4. The designer may consider the use of heat recovery ventilators suitable for a classified environment.
5. Opportunities to minimize potable water consumption throughout the plant shall be reviewed.
6. The highest potential for headworks energy savings lies in the design of the HVAC system and area classification to reduce heating demand.

C.3.5 Biosolids Management

1. Refer to the latest version of the *Niagara Region's Biosolids Management Master Plan* for details.

Appendix A - Glossary

Acronyms	Meaning
AC	Alternating Current
ACI	American Concrete Institute
AFBMA	American Friction Bearing Manufacturers
AGMA	American Gear Manufacturers Association
AISI	American Iron and Steel Institute
AMCA	Air Moving and Control Association
ANSI	American National Standards Institute
AODA	Accessibility for Ontarians with Disabilities Act
APEL	Approved Product and Equipment List
ASA	American Standards Association
ASC	Application Specific Controller
ASCE	American Society of Civil Engineers
ASHRAE	American Society of Heating, Refrigerating and Air Conditioning Engineers, Inc.
ASTM	American Society for Testing and Materials
AWWA	American Waterworks Association
BOD	Biochemical Oxygen Demand
BUNA-N	Nitrile
C/W	Complete With
C.T.	Current Transformer

Acronyms	Meaning
CAN/CGA	National Standard of Canada/Canadian Gas Association
CGA	Canadian Gas Association
CFD	Computational Fluid Dynamics
CPM	Critical Path Method
CPP	Concrete Pressure Pipe
CPU	Central Processing Unit
CPVC	Chlorinated polyvinyl chloride
CRI	Colour Rendering Index
CRN	Canadian Registration Number
CSA	Canadian Standards Association
CSO	Combined Sewer Overflows
CT	Concentration Time
DBP	Disinfection By-Products
DC	Direct Current
DI	Digital Input
DO	Dissolved Oxygen
DWF	Dry Weather Flow
DWWP	Drinking Water Works Permit
EASR	Environmental Activity and Sector Registry
ECA	Environmental Compliance Approval
EMI	Electromagnetic Interference
EPA	Environmental Protection Act
ESA	Electrical Safety Authority
FAT	Factory Acceptance Test

Acronym	Meaning
FOM	Facility Operation Manual
FRP	Fibreglass Reinforced Plastic
GAC	Granular Activated Carbon
GFI	Ground Fault Interrupt
GUI	Graphic User Interface
HAA	Haloacetic Acid
HAZOP	Hazard and Operability Review
HDPE	High Density Polyethylene
HHL	High High Level
HID	High Intensity Discharge
HMI	Human Machine Interface
HP	Horsepower
HVAC	Heating, Ventilation and Air Conditioning
HWL	High Water Level
Hz	Hertz
I/O	Input/Output
I&C	Instrumentation & Control
ICI	Industrial, Commercial and Institutional
ID	Inside Diameter
IEEE	Institute of Electrical and Electronic Engineers
ISO	International Standard
KPA	Kilopascals
LAN	Local Area Network
LCD	Liquid Crystal Display
LED	Light Emitting Diode
LCP	Local Control Panel
LL	Low Level

Acronym	Meaning
LOS	Loss of Signal
MAC	Maximum Acceptable Concentration
MCC	Motor Control Centre
MDWL	Municipal Drinking Water License
MIB	Methyl Isoborneol
MNR	Ministry of Natural Resources, Ontario
MECP	Ontario Ministry of the Environment Conservation and Parks
MOL	Ministry of Labour
MSDS	Material Safety Data Sheet
MSP	Master Servicing Plan
MTO	Ontario Ministry of Transportation
NASSCO PACP	National Association of Sewer Service Companies' Pipeline Assessment and Certification Program
N.C.	Normally Closed
N.O.	Normally Open
N.P.T.	Nominal Pipe Thread
NEMA	National Electrical Manufacturers Association
NFPA	National Fire Protection Association
NPCA	Niagara Peninsula Conservation Authority
NPSCD	Niagara Peninsula Standard Contract Document
NSF	National Sanitary Foundation
NTU	Nephelometric Turbidity Unit

Acronym	Meaning
OBC	Ontario Building Code
OD	Outside Diameter
ODWS	Ontario Drinking Water Standards
OHSA	Occupational Health and Safety Act
OESC	Ontario Electrical Safety Code
OPS	Ontario Provincial Standards
OPSD	Ontario Provincial Standard Drawings
OPSS	Ontario Provincial Standard Specifications
P&IDs	Process & Instrumentation Diagrams
PAC	Powdered Activated Carbon
PCB	Polychlorinatedbiphenols
PEO	Professional Engineers Ontario
PID	Process and Instrumentation Drawing
PLC	Programmable Logic Controller
PS	Pumping Station
PSI	Pounds Per Square Inch
PVC	Polyvinyl chloride
PVCO	Molecularly oriented polyvinyl chloride
PWM	Pulse Width Modulated
RAM	Random Access Memory
RBC	Rotating Biological Contactor
RCP	Reinforced Concrete Pipe
Region	Niagara Region

Acronym	Meaning
RPM	Rotations Per Minute
RPU	Remote Programmable Unit
SAE	Society of Automotive Engineer
SAT	Site Acceptance Test
SCADA	Supervisory Control and Data Acquisition
SO2	Sulfur Dioxide
SOP	Standard Operating Procedure
SPMDD	Standard Proctor Maximum Dry Density
SPS	Sewage Pumping Station
SUE	Subsurface Utility Engineering
THD	Total Harmonic Distortion
THM	Trihalomethane
TOP	Top of Pipe
TS	Total Solids
TSE	Technical and Scientific Equipment
TSSA	Technical Standards and Safety Authority
TTHM	Total Trihalomethanes
TWH, TWU	Type of Wire, Refer to Code, Indicates Thermoplastic Vinyl-Coated Wire that is Moisture-Resistant
TWL	Top Water Level
UL	Underwriters Laboratories
USEPA	United States Environmental Protection Agency

Acronym	Meaning
UV	Ultra-Violet
VAC	Voltage Alternating Current
VDC	Voltage Direct Current
VFD	Variable Frequency Drive
WAN	Wide Area Network
WEAO	Water Environment Association of Ontario

Acronym	Meaning
WHMIS	Workplace Hazardous Material Information System
WWF	Wet Weather Flow
WWTP	Wastewater Treatment Plant
WTP	Water Treatment Plant

Appendix B – Schematics

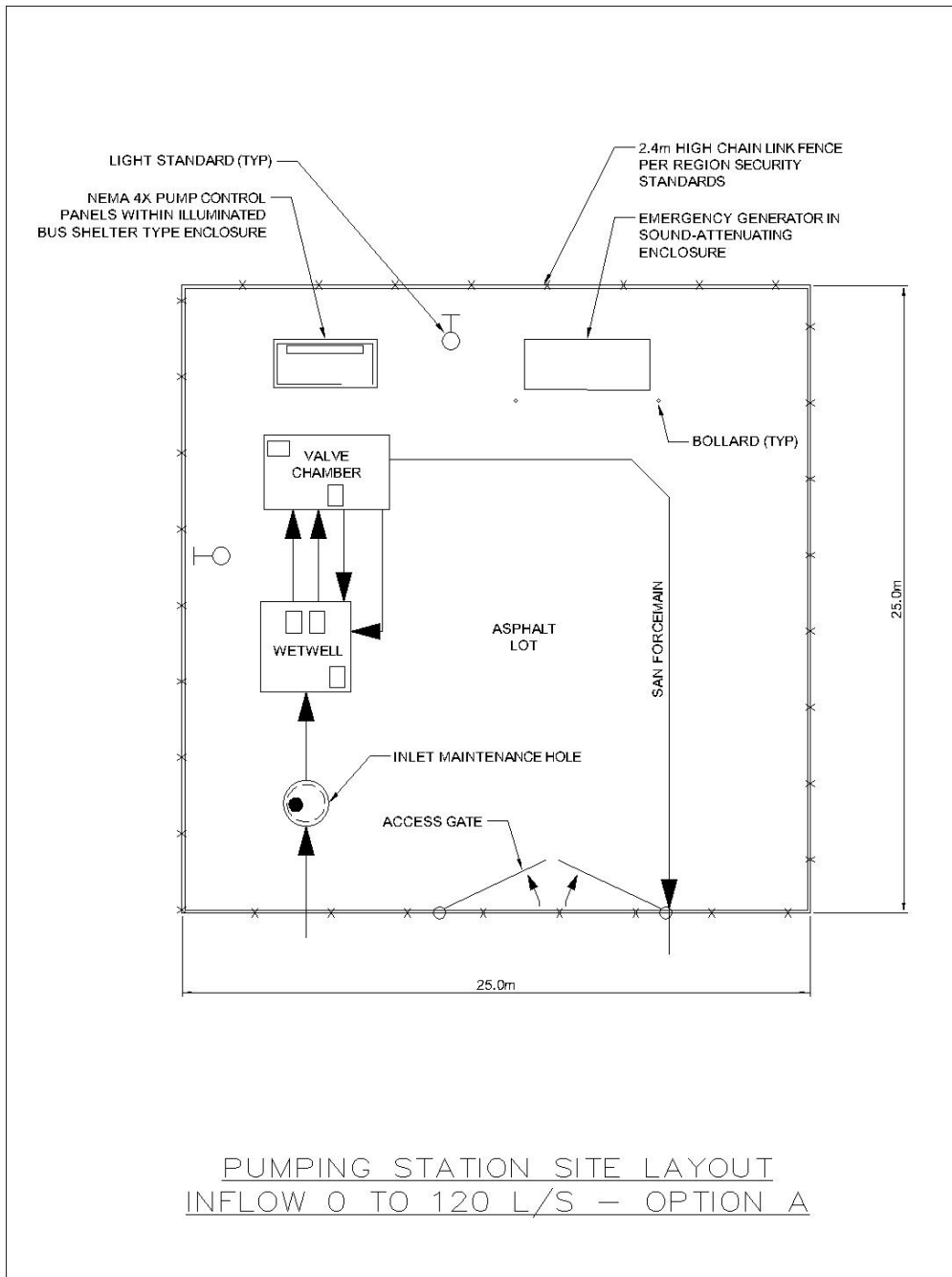

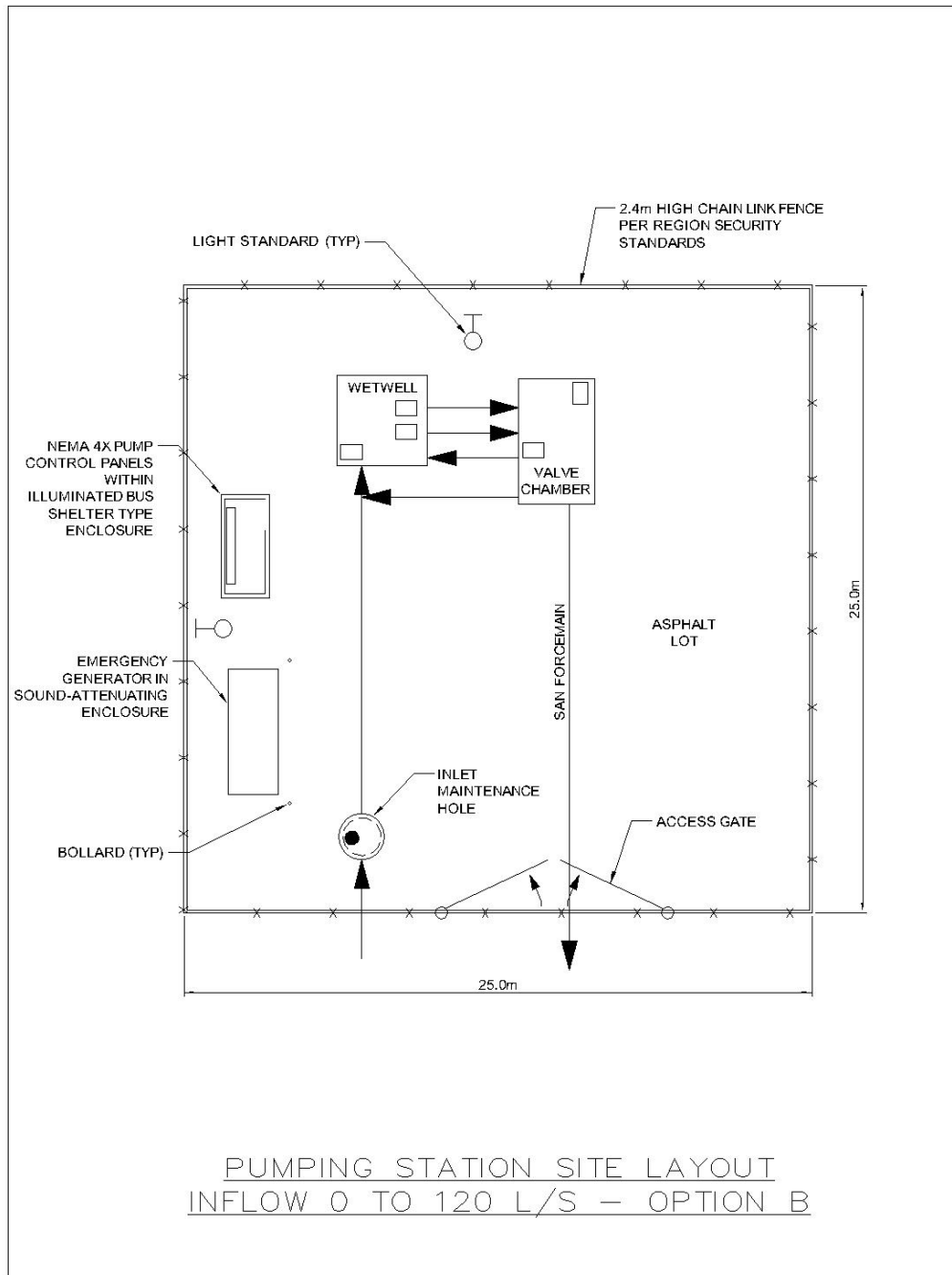

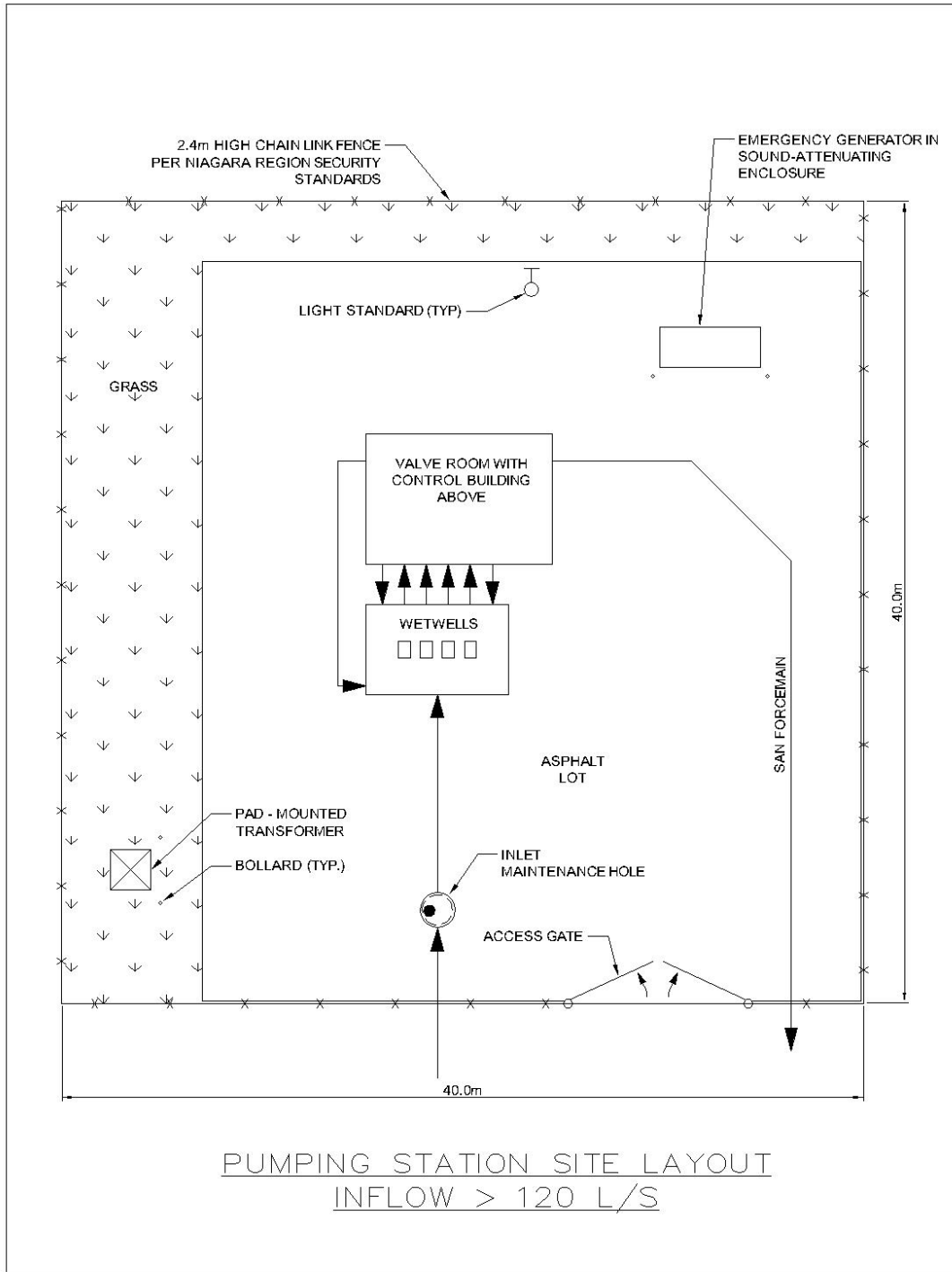

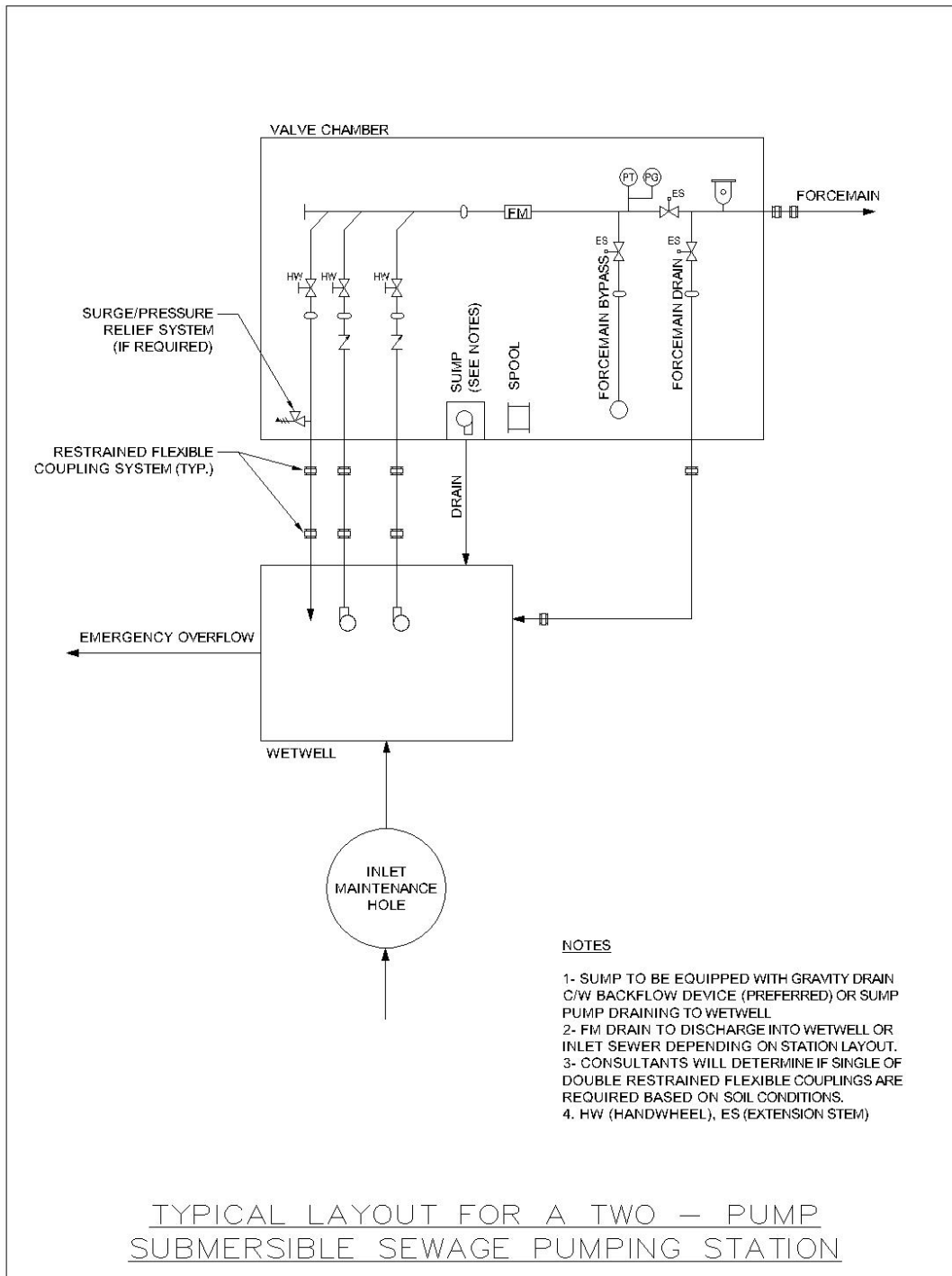

NOTES

- 1- SUMP TO BE EQUIPPED WITH GRAVITY DRAIN C/W BACKFLOW DEVICE (PREFERRED) OR SUMP PUMP DRAINING TO WETWELL.
- 2- FM DRAIN TO DISCHARGE INTO WETWELL OR INLET SEWER DEPENDING ON STATION LAYOUT.
- 3- CONSULTANTS WILL DETERMINE IF SINGLE OF DOUBLE RESTRAINED FLEXIBLE COUPLINGS ARE REQUIRED BASED ON SOIL CONDITIONS.
4. HW (HANDWHEEL), ES (EXTENSION STEM)

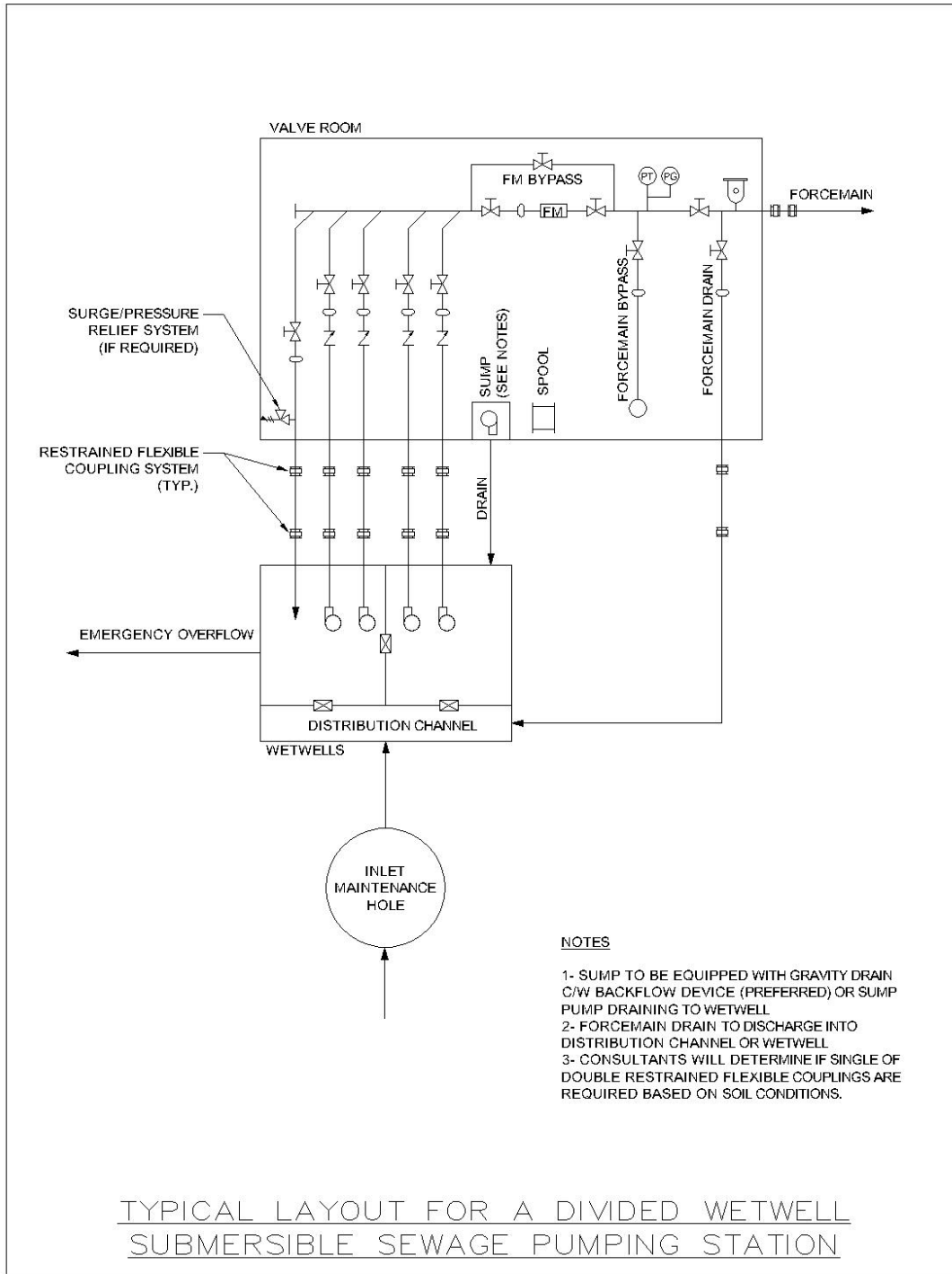

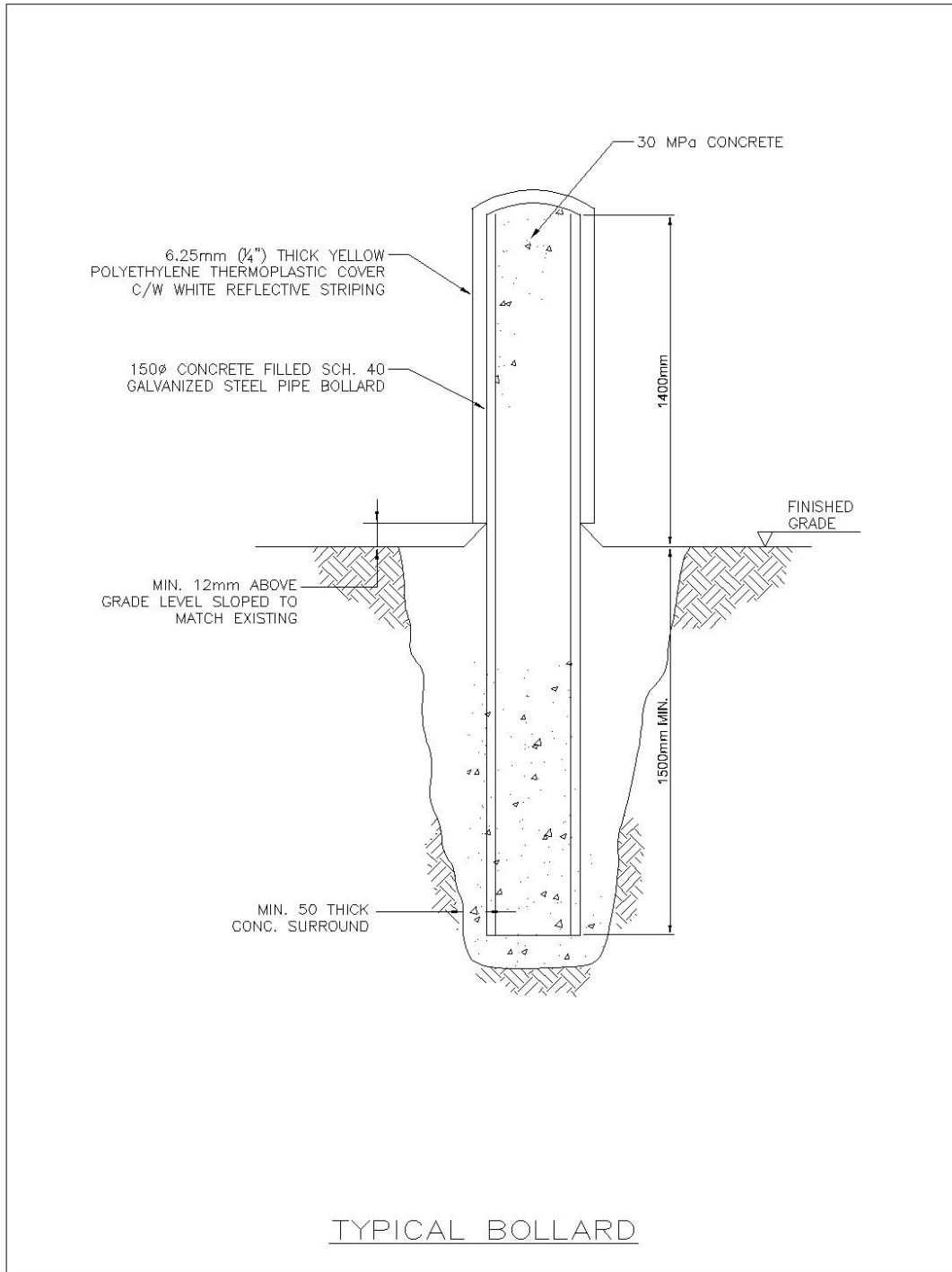

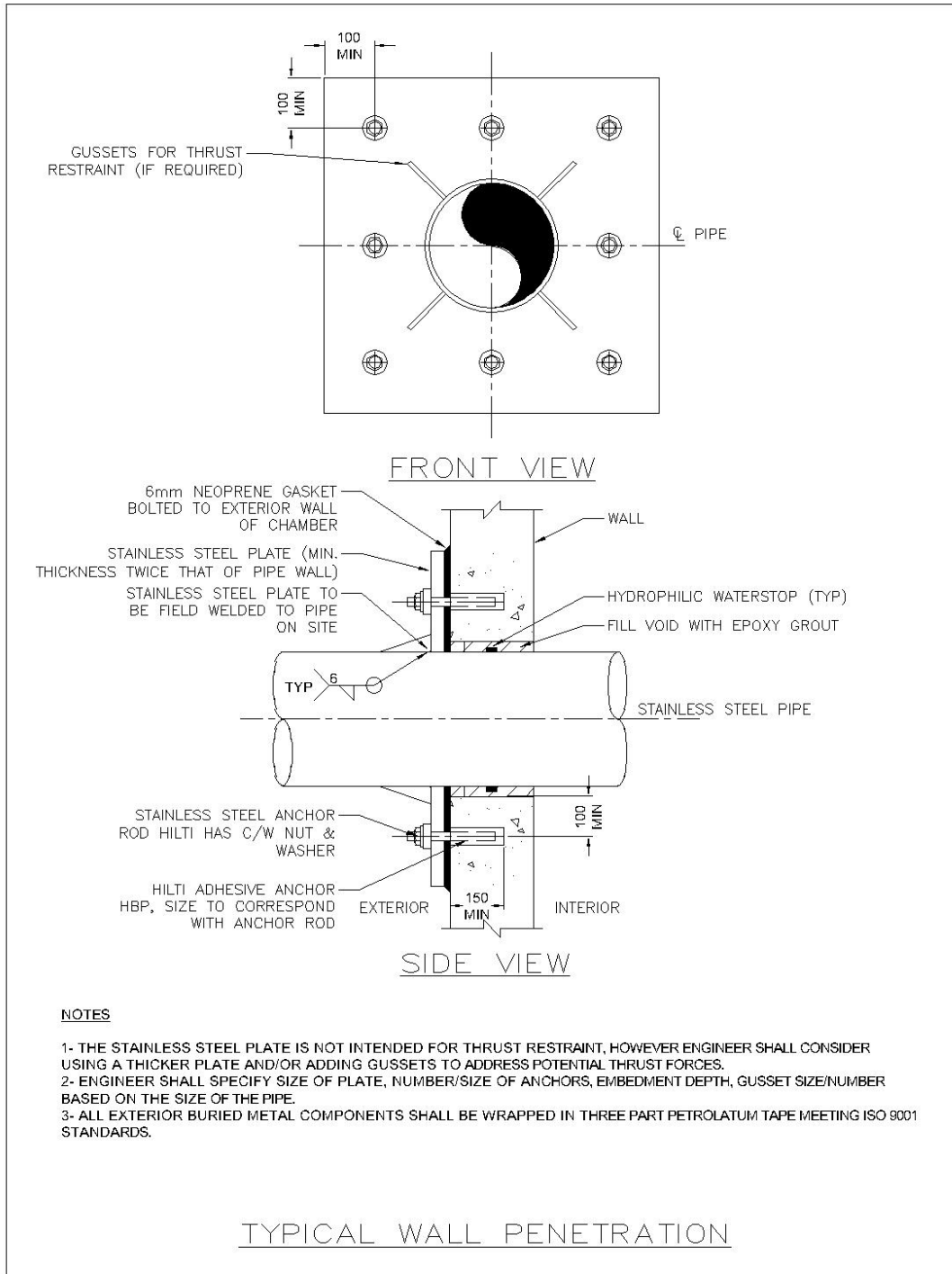

Appendix C - Acts, Codes, Standards and Guidelines

Designs shall meet the following acts, codes, standards and guidelines.

1. Ontario Ministry of the Environment Conservation and Parks (MECP) Design Guidelines
 - a) Design Guidelines for Drinking-Water Systems
 - b) Procedure for Disinfection of Drinking Water in Ontario
 - c) Design Guidelines for Sewage Works
 - d) Stormwater Management Planning and Design Manual
 - e) Water and Energy Conservation Guidance Manual for Sewage Works
 - f) Guidelines for Environmental Protection Measures at Chemical and Waste Storage Facilities
 - g) Information to be Submitted for Approval of Stationary Sources of Sound, Publication NPC-233, latest revision
2. Clean Water Act
3. Ontario Safe Drinking Water Act
4. Ontario Water Resources Act
5. Ontario Provincial Standards Specifications
6. Ontario Environmental Assessment Act
7. Ontario Environmental Protection Act
8. Ontario Building Code
9. Accessibility for Ontarians with Disabilities Act
10. Wastewater Systems Effluent Regulations
11. National Building Code of Canada
12. National Fire Code of Canada
13. National Plumbing Code
14. Canadian Standards Association
15. Guidelines for Canadian Drinking Water Quality, Health Canada
16. National Sanitary Foundation (NSF) – NSF 60 and NSF 61
17. Applicable National Fire Protection Association (NFPA) Standards
18. American National Standards Institute (ANSI)
19. American Waterworks Association (AWWA) Standards
20. Canadian Gas Association CGA B105 – Digester Gas Systems

21. Institute of Electrical and Electronic Engineers (IEEE)
22. The Instrumentation, Systems and Automation Society (ISA)
23. Canadian Electrical Code
24. Ontario Electrical Safety Code
25. Ontario Underground Infrastructure Notification Systems Act
26. American Society of Civil Engineers Standard Guideline for the Collection and Depiction of Existing Subsurface Utility Data
27. Local Area Municipal By-Laws